

SYMBOL LEGEND



BARRICADES



OR

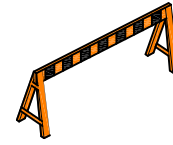

SIGN



FLASHING ARROW BOARD (FAB)



DELINEATOR POST/CONE



OR

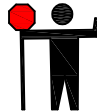

TRAFFIC CONTROL PERSON



TRAFFIC FLOW ARROW

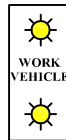

WORK VEHICLE



WORK SPACE



TEMPORARY SIDEWALK



ROADSIDE WORK AND SHOULDER WORK

RESIDENTIAL STREET AND COLLECTOR STREET

RIGHT SHOULDER WORK

NOTE : Work beyond the roadside may not require temporary traffic control signing.

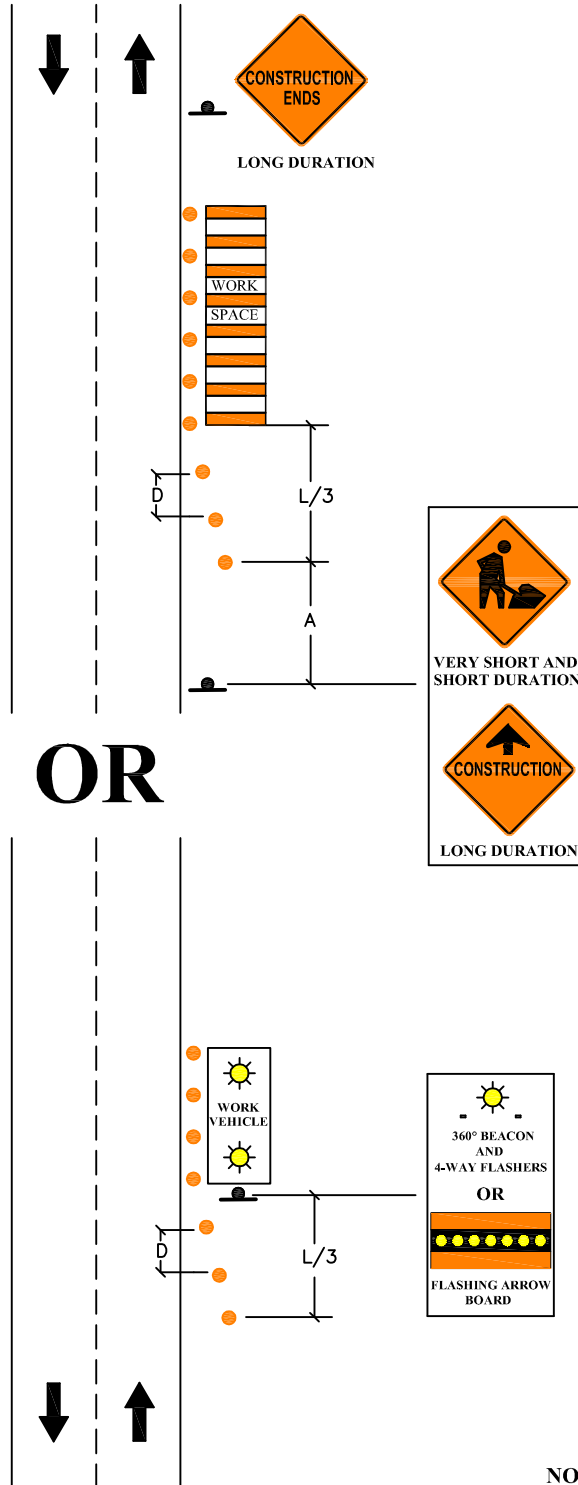

V(km/h)	A(m)	L(m)	B(m)	D(m)
50	50	30	35	8
60	50	40	45	12
70	75	60	50	15
80	100	80	60	15
90	100	105	65	18
100	125	125	70	18
110	125	145	75	20

WHERE:
V=SPEED LIMIT
A=SPACING BETWEEN SIGNS
L=LENGTH OF TAPER
B=LENGTH OF LONGITUDINAL BUFFER SPACE
D=SPACING BETWEEN DELINEATION DEVICES

NOT TO SCALE

CITY OF BRANDON
ENGINEERING DEPARTMENT



DATE: AUGUST 01, 2001
 REVISED: FEBRUARY 10, 2006
 DRAWING #: TCM SECTION 6.2

REFERENCE MUTCD: FIGURE D4 - 2

ROADSIDE WORK AND SHOULDER WORK ON A TWO-LANE STREET

RESIDENTIAL STREET AND COLLECTOR STREET

ENCROACHMENT IN RIGHT LANE

V(km/h)	A(m)	L(m)	B(m)	D(m)
50	50	30	35	8
60	50	40	45	12
70	75	60	50	15
80	100	80	60	15
90	100	105	65	18
100	125	125	70	18
110	125	145	75	20

WHERE:

V=SPEED LIMIT

A=SPACING BETWEEN SIGNS

L=LENGTH OF TAPER

B=LENGTH OF LONGITUDINAL BUFFER SPACE

D=SPACING BETWEEN DELINEATION DEVICES

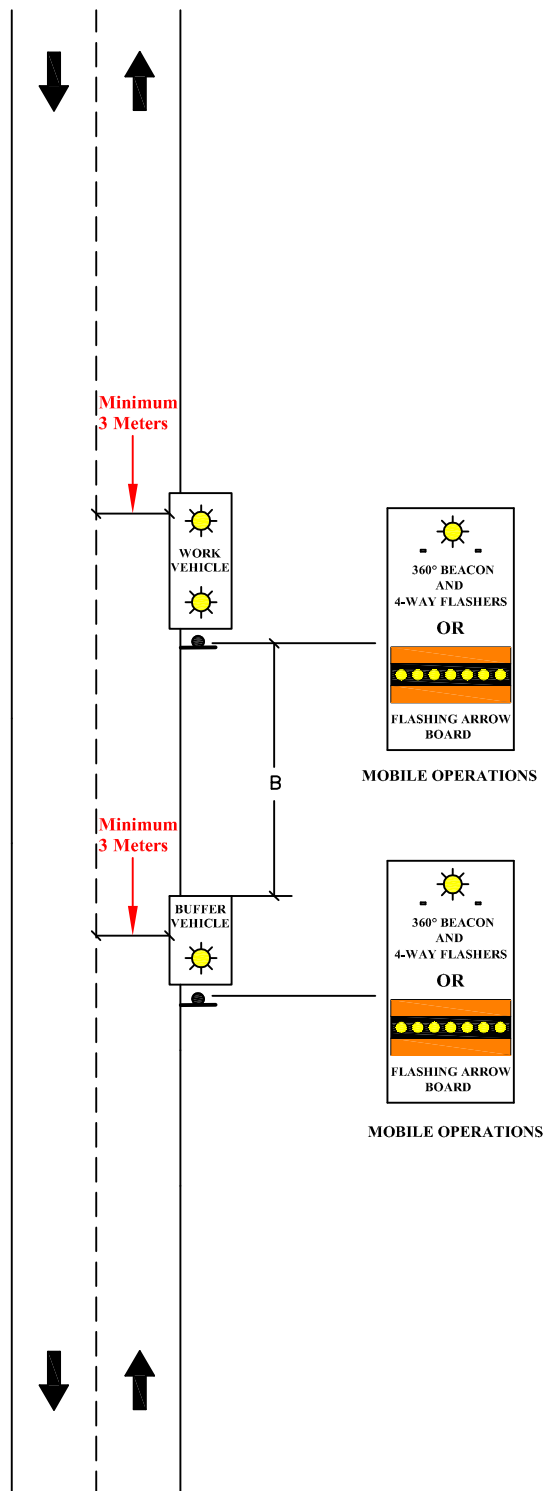

NOT TO SCALE

CITY OF BRANDON
ENGINEERING DEPARTMENT



DATE: AUGUST 01, 2001
REVISED: MARCH 8, 2006
DRAWING #: TTCM SECTION 6.3

REFERENCE MUTCD: FIGURE D4 - 3

ROADSIDE WORK AND SHOULDER WORK ON A TWO-LANE STREET

RESIDENTIAL STREET

ENCROACHMENT IN RIGHT LANE

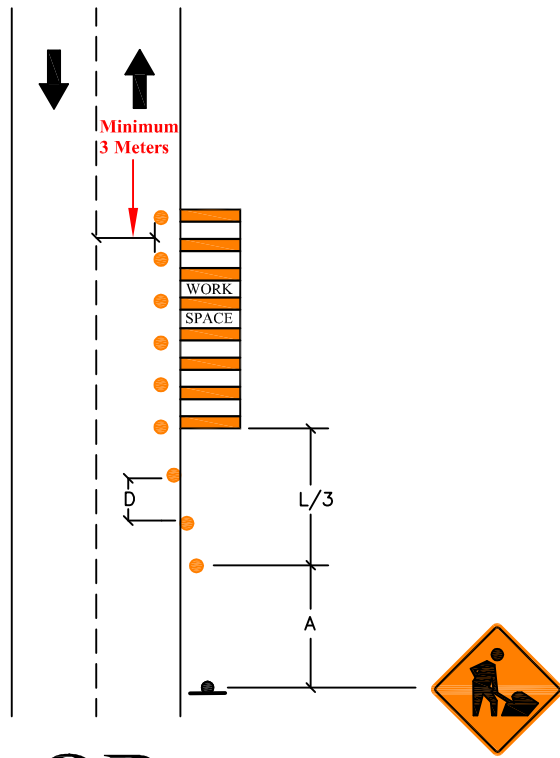

VERY SHORT AND SHORT DURATION

OR

V(km/h)	A(m)	L(m)	B(m)	D(m)
50	50	30	35	8
60	50	40	45	12
70	75	60	50	15
80	100	80	60	15
90	100	105	65	18
100	125	125	70	18
110	125	145	75	20

WHERE:

V=SPEED LIMIT

A=SPACING BETWEEN SIGNS

L=LENGTH OF TAPER

B=LENGTH OF LONGITUDINAL BUFFER SPACE

D=SPACING BETWEEN DELINEATION DEVICES

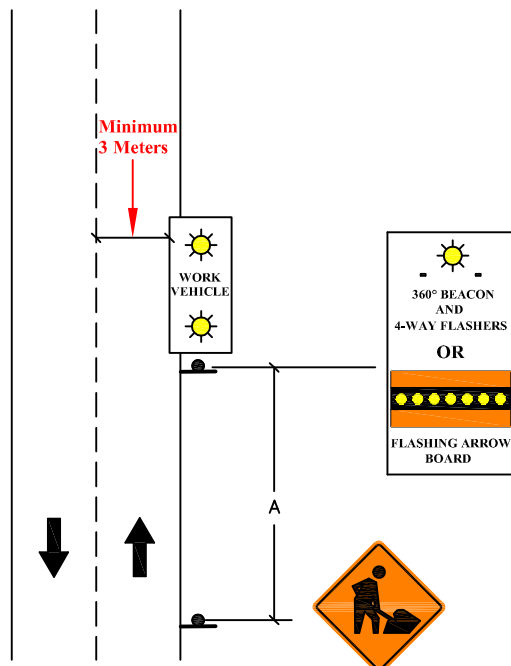

VERY SHORT AND SHORT DURATION

NOT TO SCALE

CITY OF BRANDON
ENGINEERING DEPARTMENT



DATE: AUGUST 01, 2001
REVISED: FEBRUARY 10, 2006
DRAWING #: TTCM SECTION 6.4

REFERENCE MUTCD: FIGURE D4 - 4

ROADSIDE WORK AND SHOULDER WORK ON A TWO-LANE STREET

COLLECTOR STREET

ENCROACHMENT IN RIGHT LANE

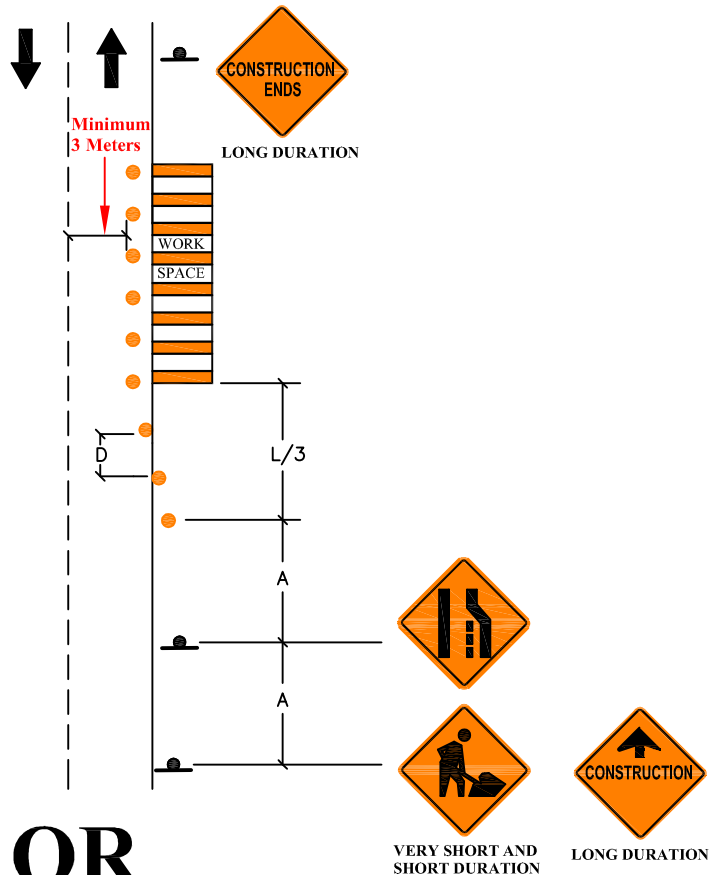

OR

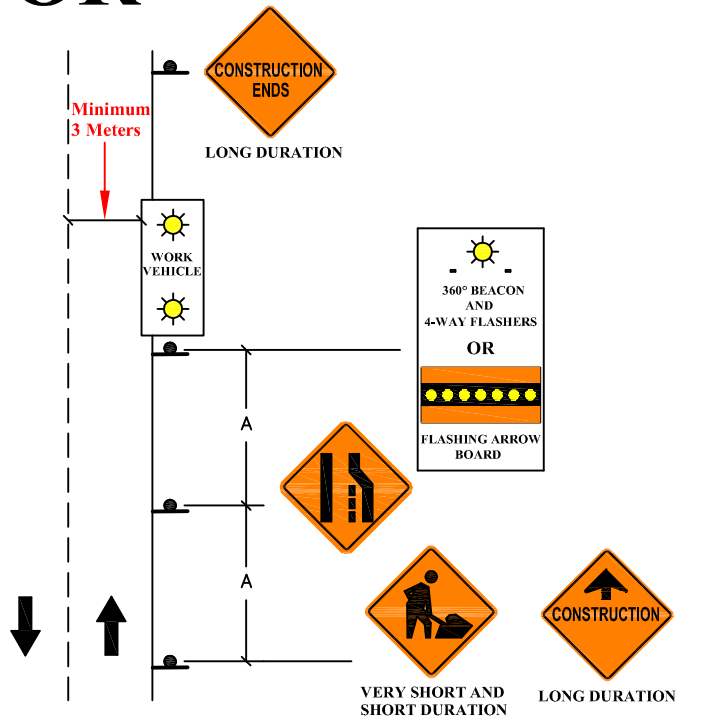

V(km/h)	A(m)	L(m)	B(m)	D(m)
50	50	30	35	8
60	50	40	45	12
70	75	60	50	15
80	100	80	60	15
90	100	105	65	18
100	125	125	70	18
110	125	145	75	20

WHERE:
 V=SPEED LIMIT
 A=SPACING BETWEEN SIGNS
 L=LENGTH OF TAPER
 B=LENGTH OF LONGITUDINAL BUFFER SPACE
 D=SPACING BETWEEN DELINEATION DEVICES

NOT TO SCALE

**CITY OF BRANDON
 ENGINEERING DEPARTMENT**



DATE: AUGUST 01, 2001
 REVISED: FEBRUARY 10, 2006
 DRAWING #: TTCM SECTION 6.5

REFERENCE MUTCD: FIGURE D4 - 5

SINGLE LANE CLOSED

RESIDENTIAL STREET

TWO-LANE ROAD-RIGHT LANE CLOSED

YIELD TO ONCOMING TRAFFIC

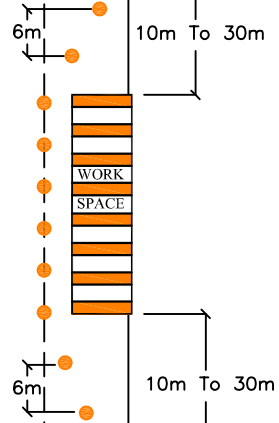
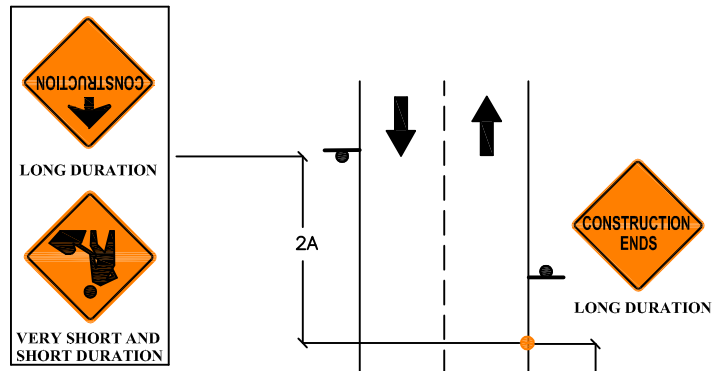

V(km/h)	A(m)	L(m)	B(m)	D(m)
50	50	30	35	8
60	50	40	45	12
70	75	60	50	15
80	100	80	60	15
90	100	105	65	18
100	125	125	70	18
110	125	145	75	20

WHERE:
 V=SPEED LIMIT
 A=SPACING BETWEEN SIGNS
 L=LENGTH OF TAPER
 B=LENGTH OF LONGITUDINAL BUFFER SPACE
 D=SPACING BETWEEN DELINEATION DEVICES



NOT TO SCALE



**SINGLE LANE CLOSED
TRAFFIC CONTROL PERSON'S**

**COLLECTOR STREET AND
ARTERIAL STREET**

TWO-LANE STREET - RIGHT LANE CLOSED

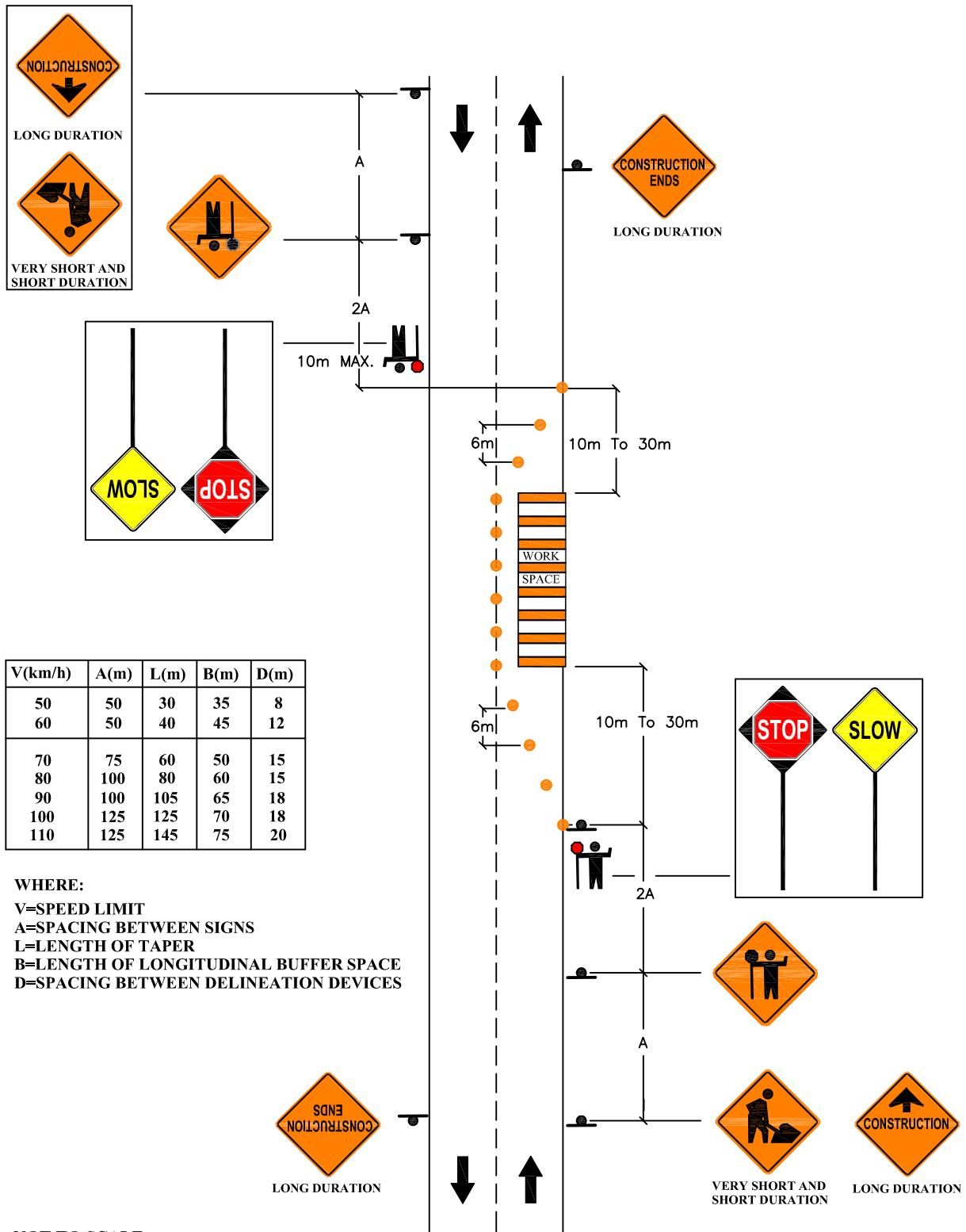

**ROADSIDE WORK AND SHOULDER
WORK ON MULTI-LANE ROADS**

**COLLECTOR STREET AND
ARTERIAL STREET**

ENCROACHMENT IN RIGHT LANE

V(km/h)	A(m)	L(m)	B(m)	D(m)
50	50	30	35	8
60	50	40	45	12
70	75	60	50	15
80	100	80	60	15
90	100	105	65	18
100	125	125	70	18
110	125	145	75	20

WHERE:
V=SPEED LIMIT
A=SPACING BETWEEN SIGNS
L=LENGTH OF TAPER
B=LENGTH OF LONGITUDINAL BUFFER SPACE
D=SPACING BETWEEN DELINEATION DEVICES

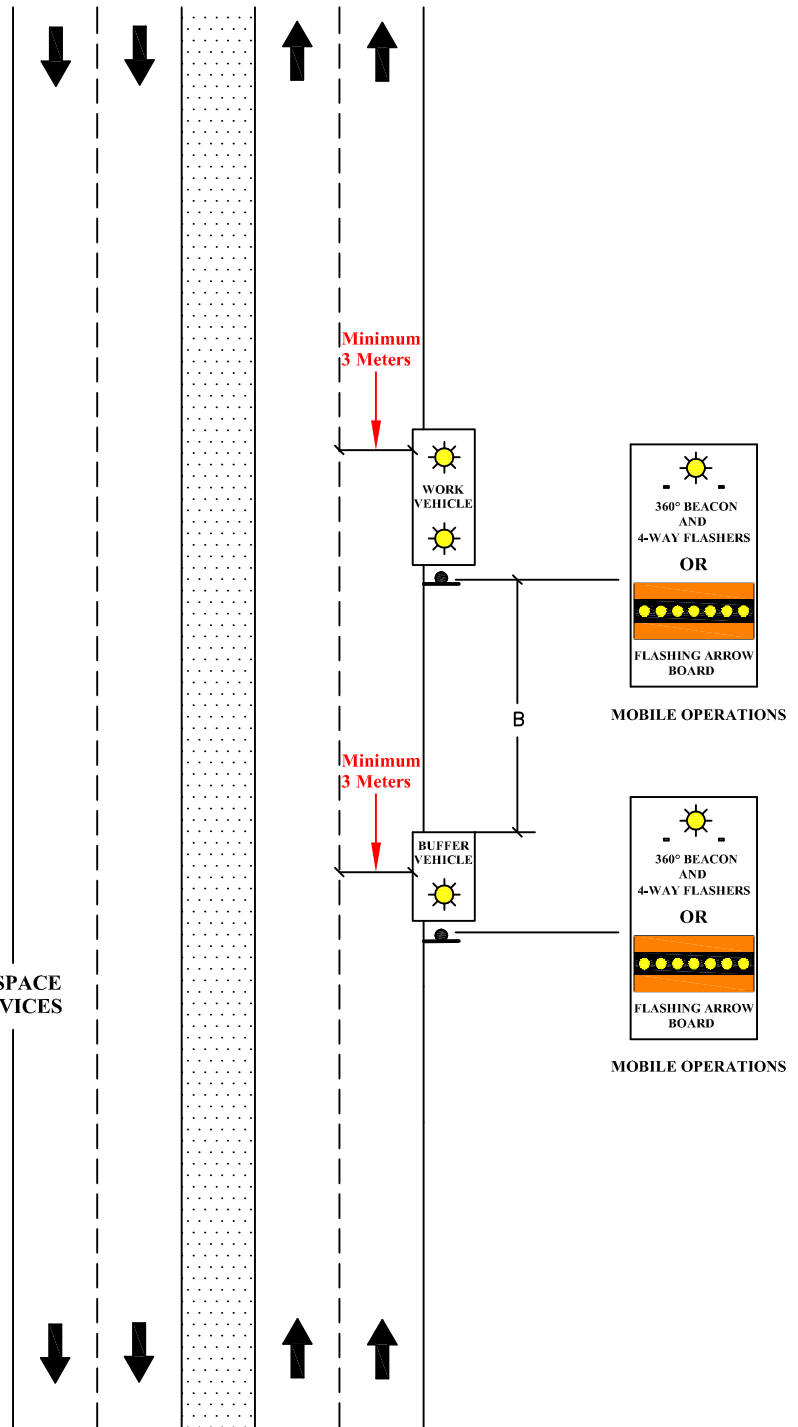

NOT TO SCALE

**CITY OF BRANDON
ENGINEERING DEPARTMENT**



DATE: AUGUST 01, 2001
 REVISED: MARCH 8, 2006
 DRAWING #: TCM SECTION 6.8

REFERENCE MUTCD: FIGURE D4 - 11

ROADSIDE WORK AND SHOULDER WORK ON A MULTI-LANE ROAD

COLLECTOR STREET AND ARTERIAL STREET

ENCROACHMENT IN RIGHT LANE

V(km/h)	A(m)	L(m)	B(m)	D(m)
50	50	30	35	8
60	50	40	45	12
70	75	60	50	15
80	100	80	60	15
90	100	105	65	18
100	125	125	70	18
110	125	145	75	20

WHERE:

V=SPEED LIMIT

A=SPACING BETWEEN SIGNS

L=LENGTH OF TAPER

B=LENGTH OF LONGITUDINAL BUFFER SPACE

D=SPACING BETWEEN DELINEATION DEVICES

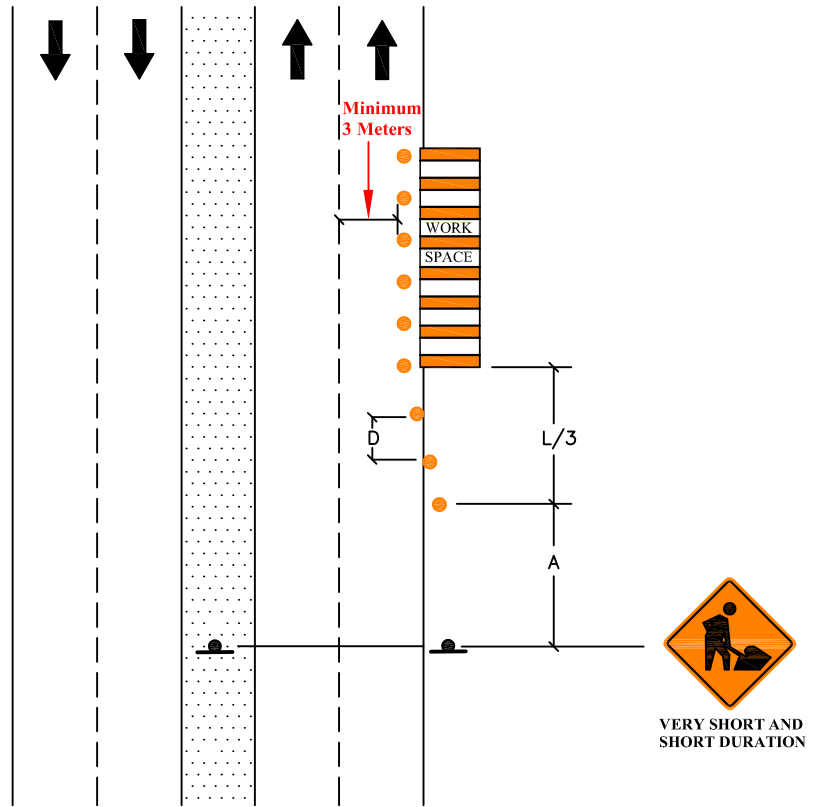

OR

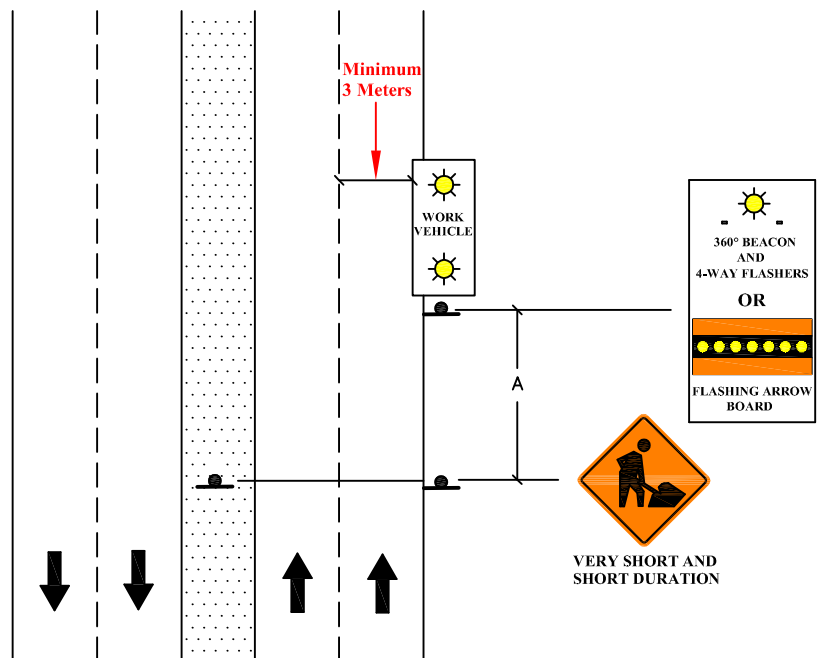

NOT TO SCALE

**CITY OF BRANDON
ENGINEERING DEPARTMENT**



DATE: AUGUST 01, 2001
REVISED: MARCH 8, 2006
DRAWING #: TCM SECTION 6.9

REFERENCE MUTCD: FIGURE D4 - 13

ROADSIDE WORK AND SHOULDER WORK ON A MULTI-LANE ROAD

COLLECTOR STREET AND ARTERIAL STREET

ENCROACHMENT IN RIGHT LANE

LONG DURATION

V(km/h)	A(m)	L(m)	B(m)	D(m)
50	50	30	35	8
60	50	40	45	12
70	75	60	50	15
80	100	80	60	15
90	100	105	65	18
100	125	125	70	18
110	125	145	75	20

WHERE:

V=SPEED LIMIT

A=SPACING BETWEEN SIGNS

L=LENGTH OF TAPER

B=LENGTH OF LONGITUDINAL BUFFER SPACE

D=SPACING BETWEEN DELINEATION DEVICES

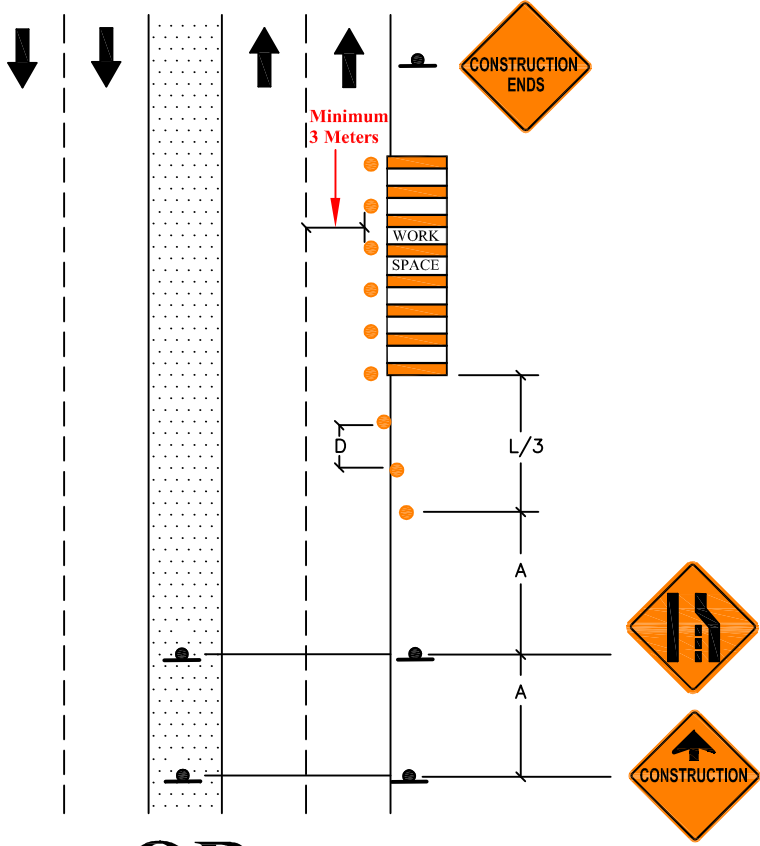

OR

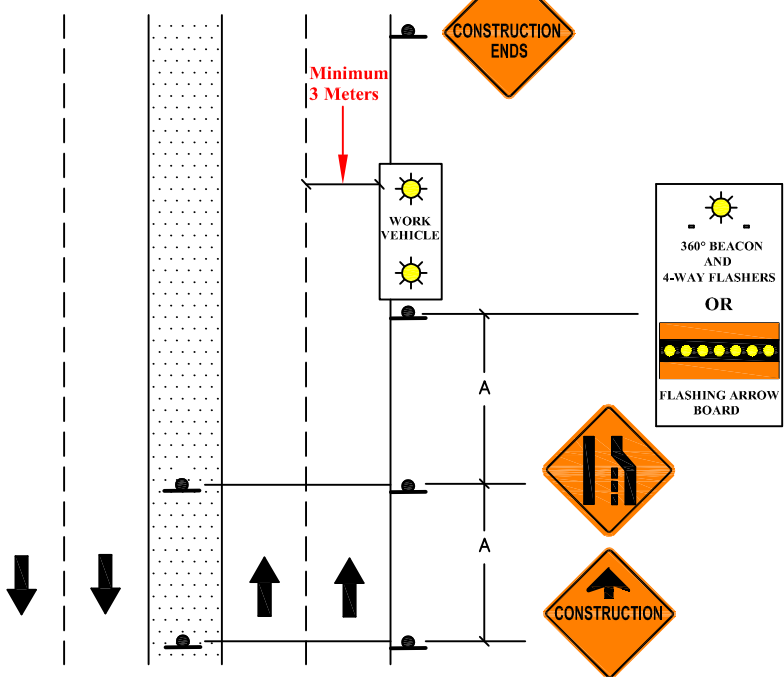

NOT TO SCALE

**CITY OF BRANDON
ENGINEERING DEPARTMENT**



DATE: AUGUST 01, 2001
REVISED: FEBRUARY 10, 2006
DRAWING #: TCM SECTION 6.10

REFERENCE MUTCD: FIGURE D4 - 15

SINGLE LANE CLOSED

COLLECTOR STREET AND ARTERIAL STREET

MULTI-LANE ROAD - RIGHT LANE CLOSED

Vehicle Speed ≤ 60 km/h

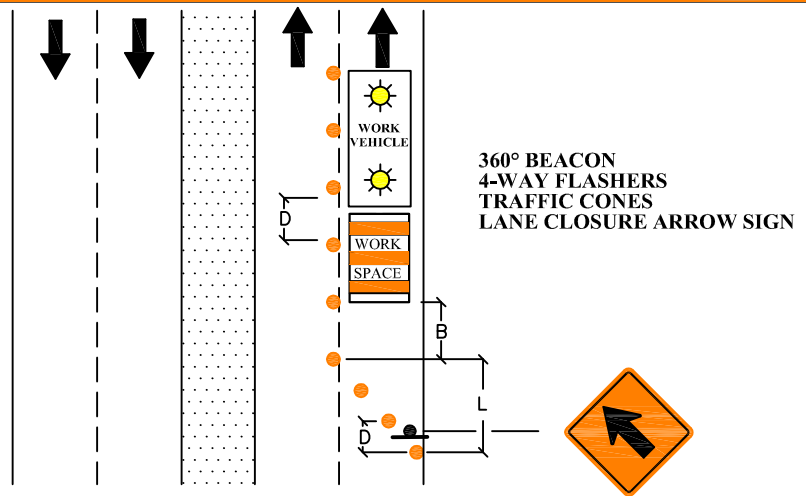

OR

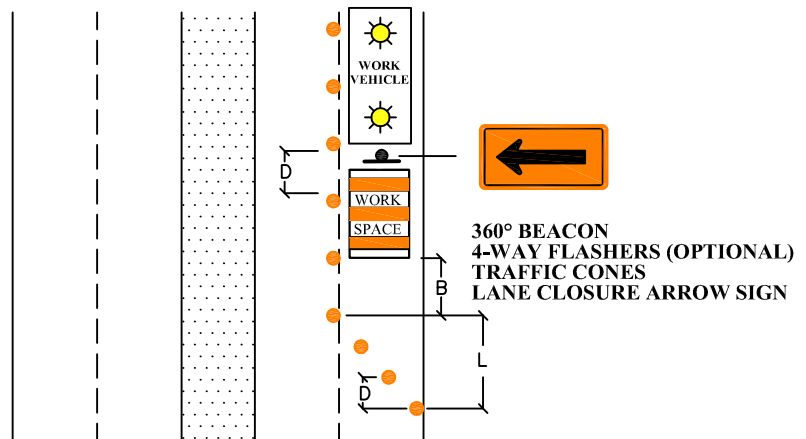

OR

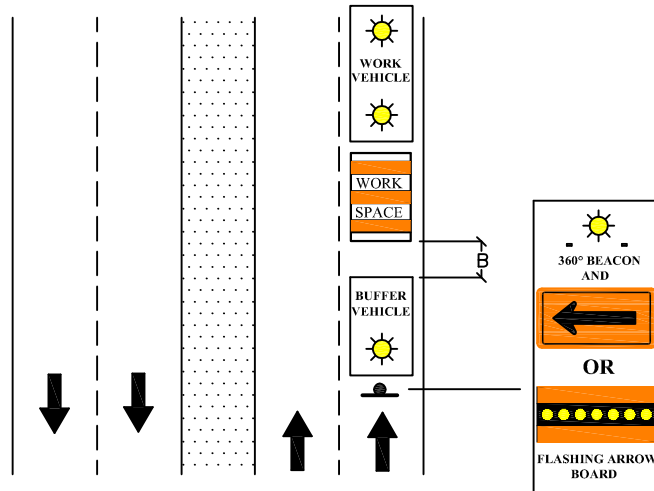

V(km/h)	A(m)	L(m)	B(m)	D(m)
50	50	30	35	8
60	50	40	45	12

WHERE:
 V=SPEED LIMIT
 A=SPACING BETWEEN SIGNS
 L=LENGTH OF TAPER
 B=LENGTH OF LONGITUDINAL BUFFER SPACE
 D=SPACING BETWEEN DELINEATION DEVICES

NOT TO SCALE

**CITY OF BRANDON
 ENGINEERING DEPARTMENT**



DATE: AUGUST 01, 2001
 REVISED: FEBRUARY 10, 2006
 DRAWING #: TCM SECTION 6.11

REFERENCE MUTCD: FIGURE D4 - 22A

**SINGLE LANE CLOSED
SHORT DURATION**

**COLLECTOR STREET AND
ARTERIAL STREET**

MULTI-LANE ROAD-RIGHT LANE CLOSED

V(km/h)	A(m)	L(m)	B(m)	D(m)
50	50	30	35	8
60	50	40	45	12
70	75	60	50	15
80	100	80	60	15
90	100	105	65	18
100	125	125	70	18
110	125	145	75	20

WHERE:
 V=SPEED LIMIT
 A=SPACING BETWEEN SIGNS
 L=LENGTH OF TAPER
 B=LENGTH OF LONGITUDINAL BUFFER SPACE
 D=SPACING BETWEEN DELINEATION DEVICES

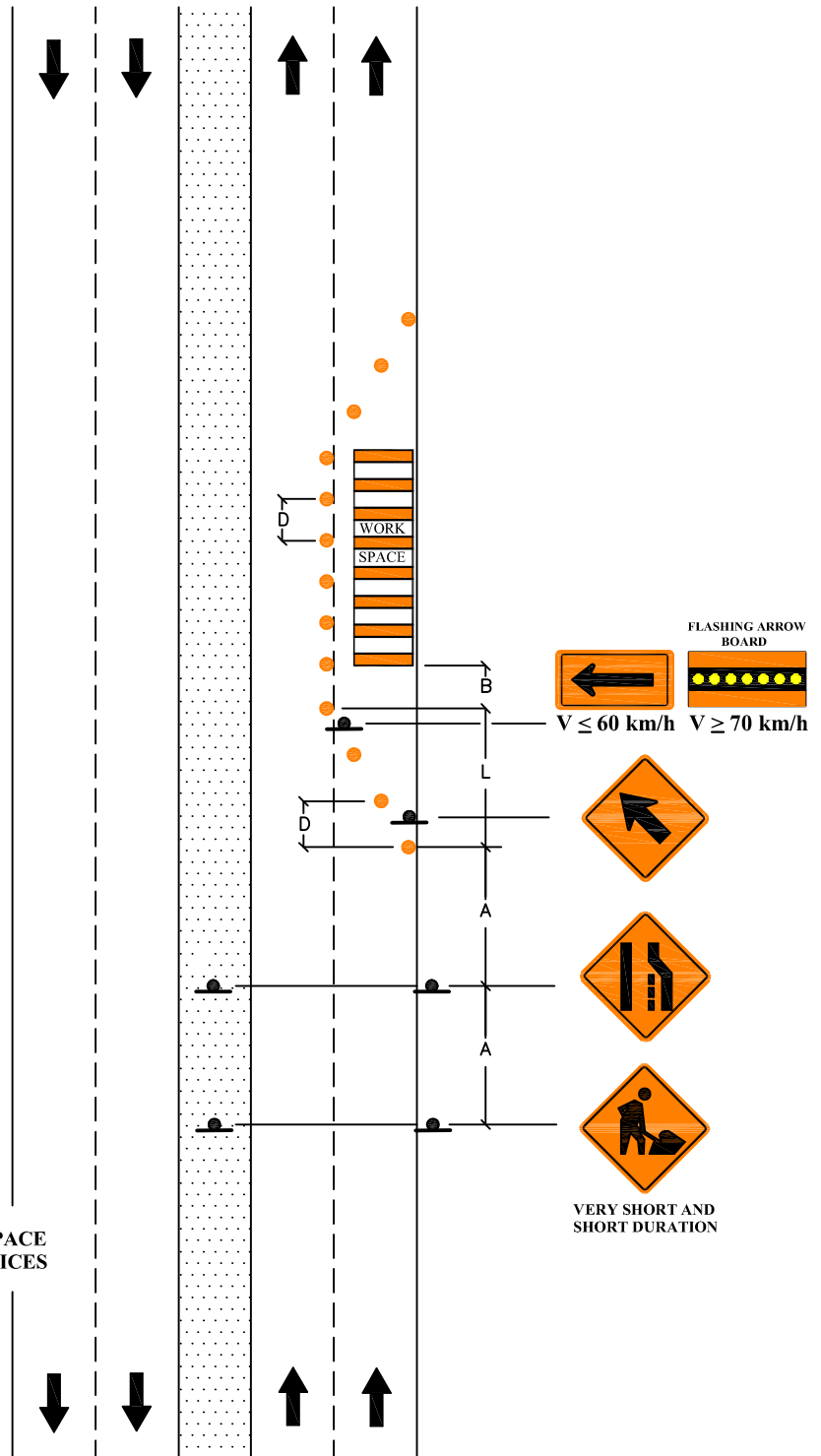

NOT TO SCALE



**SINGLE LANE CLOSED
LONG DURATION**

**COLLECTOR STREET AND
ARTERIAL STREET**

MULTI-LANE ROAD-RIGHT LANE CLOSED

V(km/h)	A(m)	L(m)	B(m)	D(m)
50	50	30	35	8
60	50	40	45	12
70	75	60	50	15
80	100	80	60	15
90	100	105	65	18
100	125	125	70	18
110	125	145	75	20

WHERE:
 V=SPEED LIMIT
 A=SPACING BETWEEN SIGNS
 L=LENGTH OF TAPER
 B=LENGTH OF LONGITUDINAL BUFFER SPACE
 D=SPACING BETWEEN DELINEATION DEVICES

NOT TO SCALE

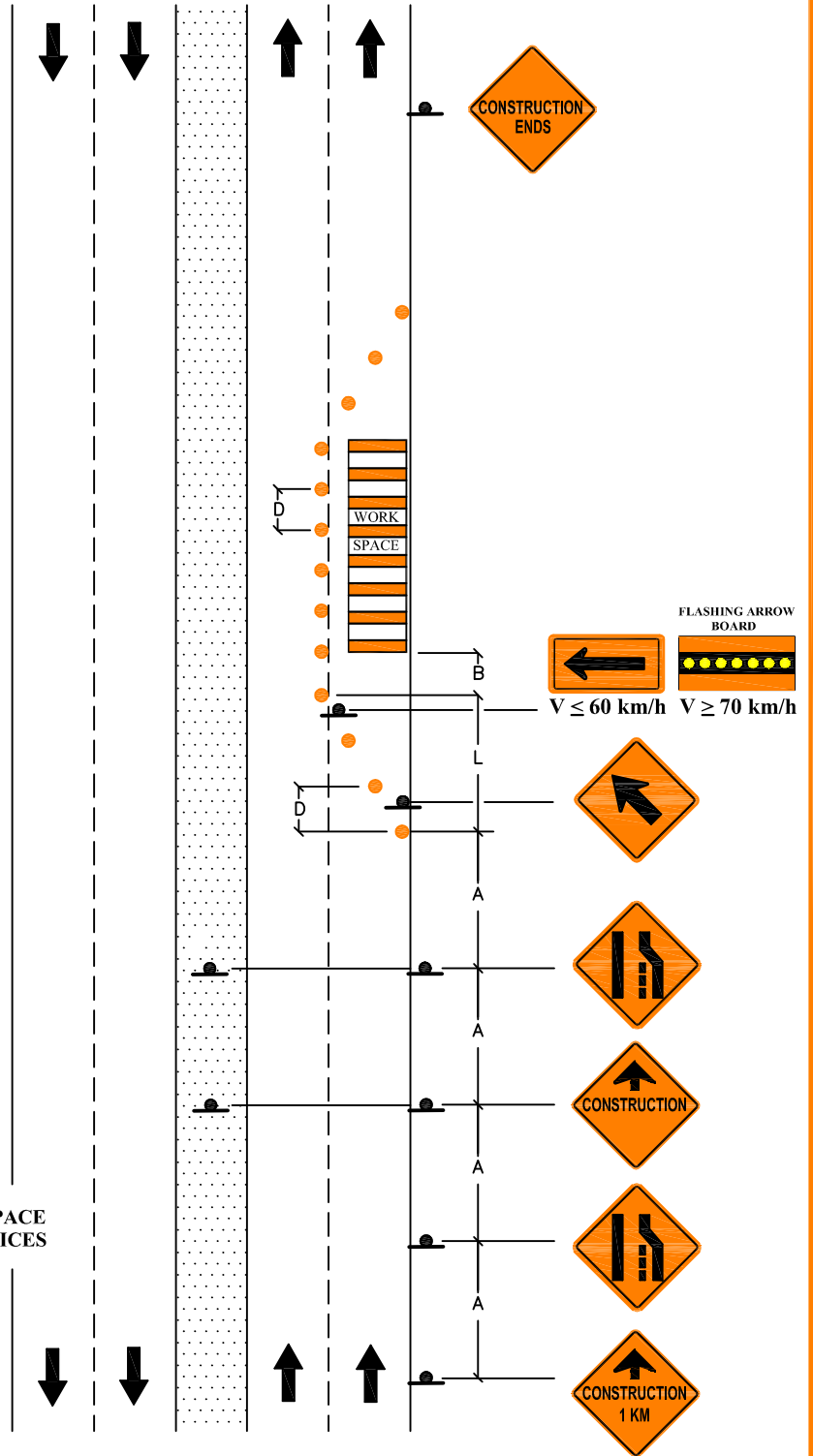

**ROADSIDE WORK AND SHOULDER
WORK ON MULTI-LANE ROADS**

**COLLECTOR STREET AND
ARTERIAL STREET**

WORK IN MEDIAN

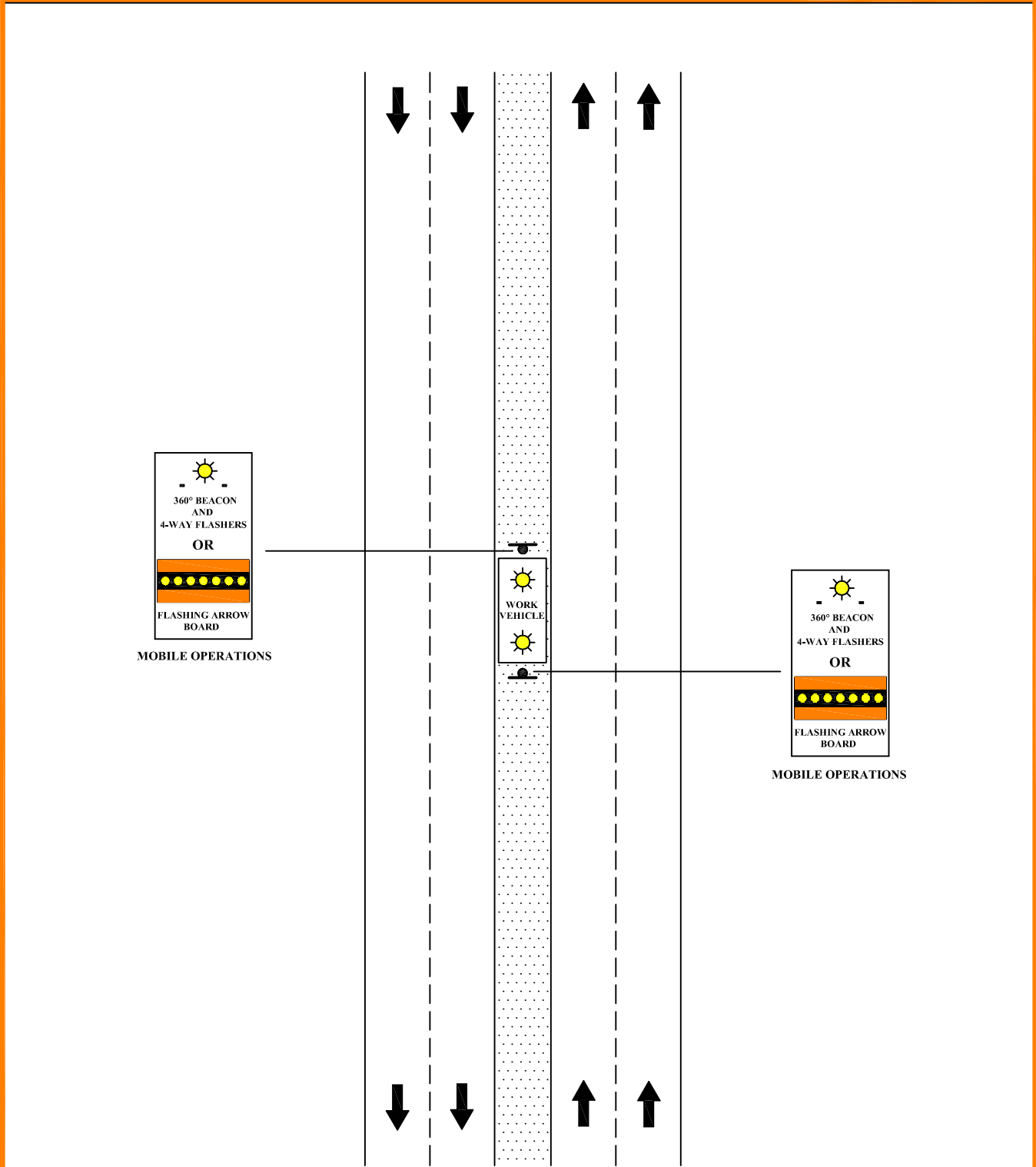

NOT TO SCALE

**CITY OF BRANDON
ENGINEERING DEPARTMENT**



DATE: AUGUST 01, 2001
REVISED: MARCH 8, 2006
DRAWING #: TTCM SECTION 6.14

REFERENCE MUTCD: FIGURE D4 - 8

**ROADSIDE WORK AND SHOULDER
WORK ON MULTI-LANE ROADS**

**COLLECTOR STREET AND
ARTERIAL STREET**

WORK IN MEDIAN

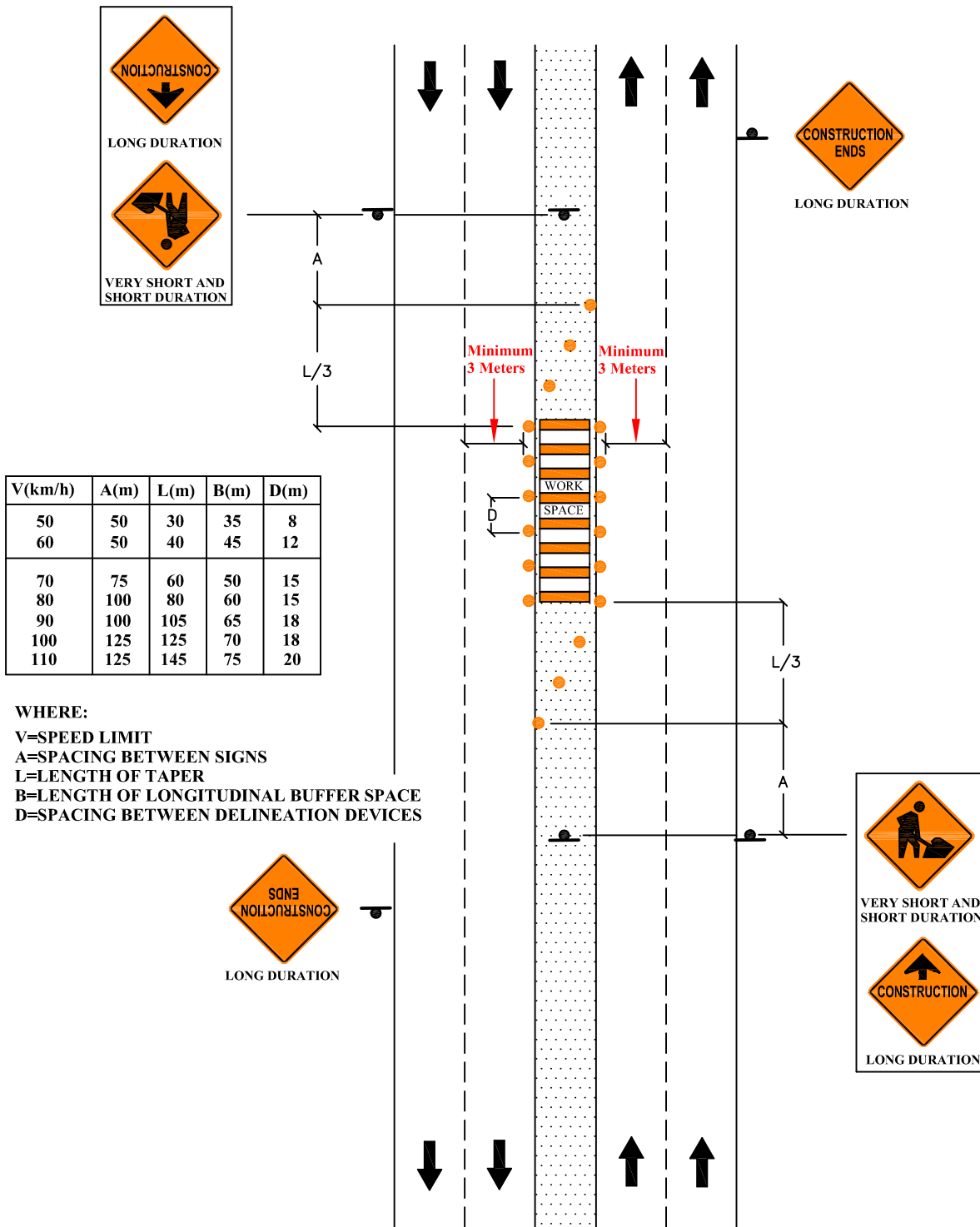

NOT TO SCALE

**CITY OF BRANDON
ENGINEERING DEPARTMENT**



DATE: AUGUST 01, 2001
 REVISED: FEBRUARY 10, 2006
 DRAWING #: TTCM SECTION 6.15

REFERENCE MUTCD: FIGURE D4 - 9

ROADSIDE WORK AND SHOULDER WORK ON MULTI-LANE ROADS

COLLECTOR STREET AND ARTERIAL STREET

WORK IN MEDIAN - ONE DIRECTION LANE CLOSED

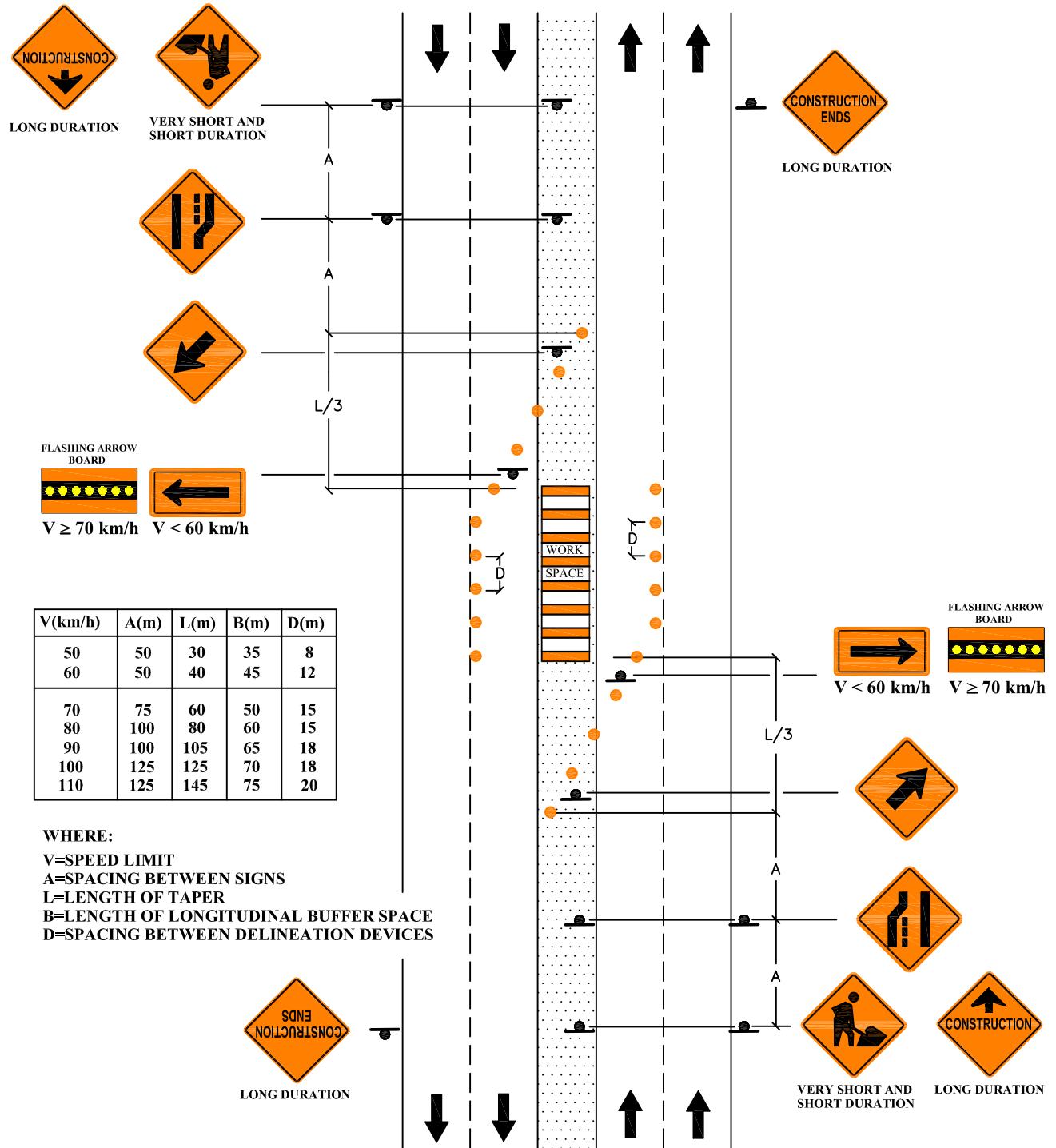

LANE CLOSED AT INTERSECTION ON TWO-LANE ROADS

RESIDENTIAL STREET

NEAR SIDE LANE CLOSED

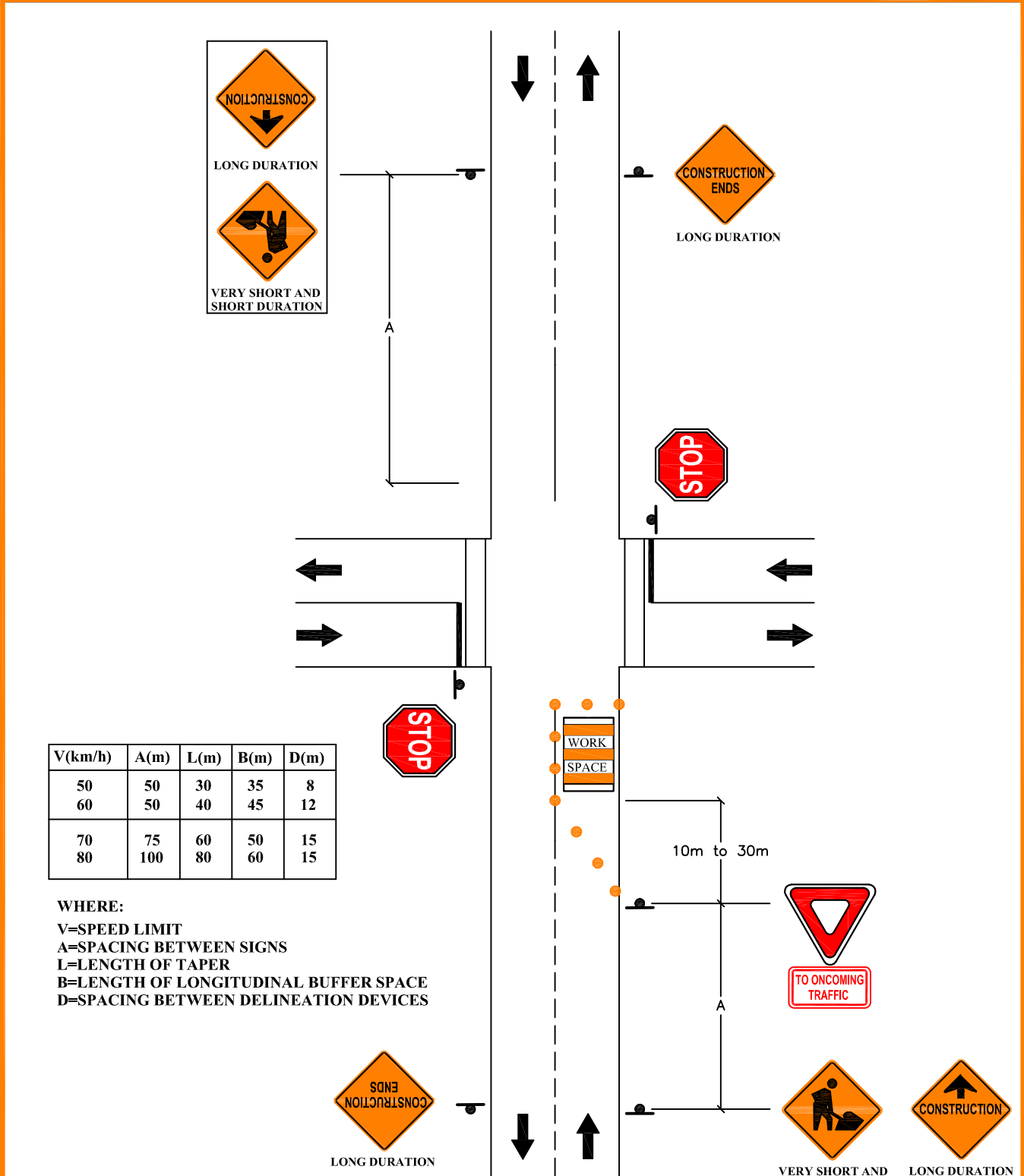

**CITY OF BRANDON
 ENGINEERING DEPARTMENT**



DATE: AUGUST 01, 2001
 REVISED: FEBRUARY 10, 2006
 DRAWING #: TCM SECTION 6.17

LANE CLOSED AT INTERSECTION ON TWO-LANE ROADS

COLLECTOR STREET AND ARTERIAL STREET

NEAR SIDE LANE CLOSED

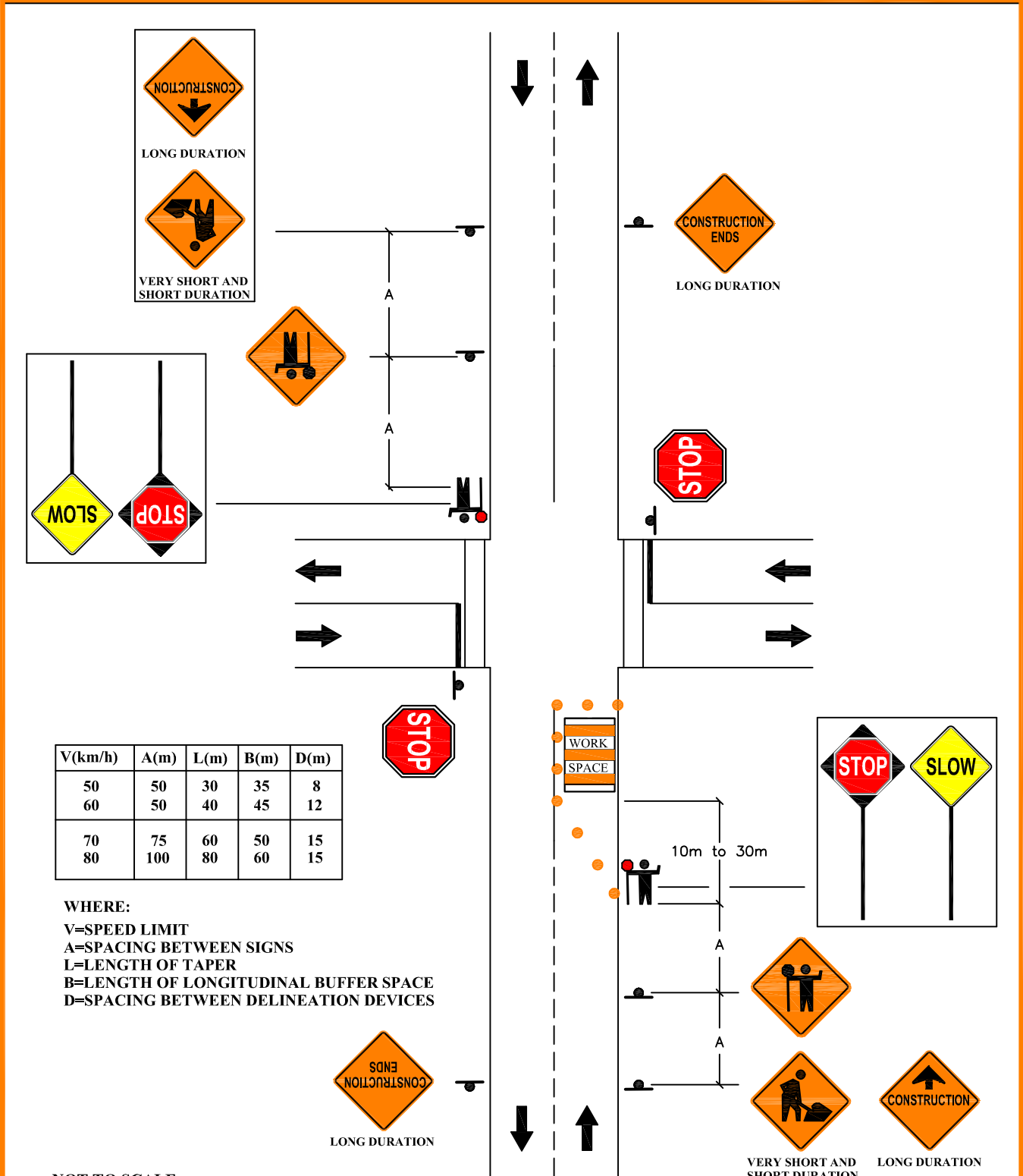

**CITY OF BRANDON
 ENGINEERING DEPARTMENT**



DATE: AUGUST 01, 2001
 REVISED: FEBRUARY 10, 2006
 DRAWING #: TCM SECTION 6.18

REFERENCE MUTCD: FIGURE D4 - 51

LANE CLOSED AT INTERSECTION ON TWO-LANE ROADS

COLLECTOR STREET AND ARTERIAL STREET

FAR SIDE LANE CLOSED

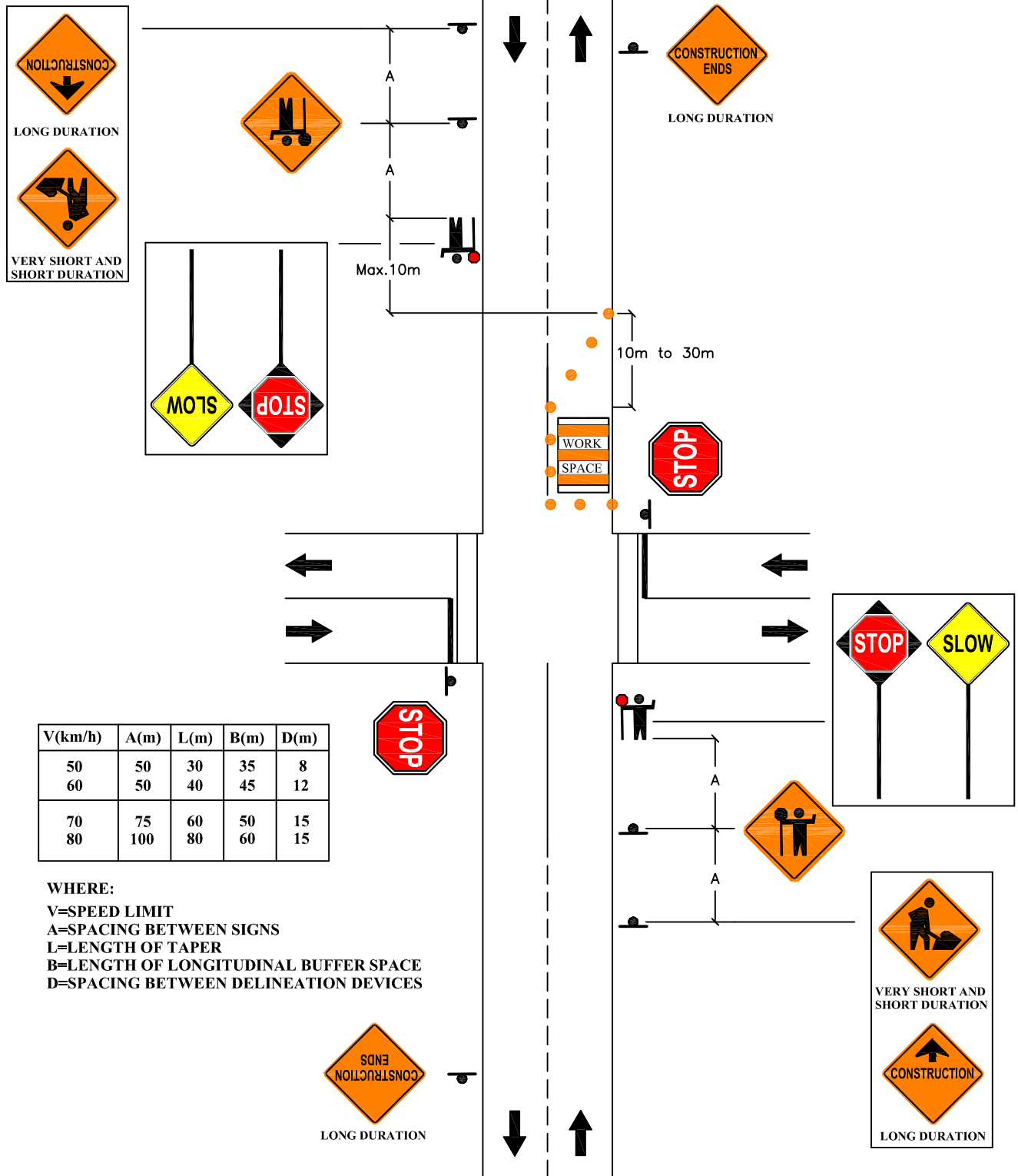

**INTERSECTION NEAR SIDE LANE
CLOSED ON MULTI-LANE ROADS**

**COLLECTOR STREET AND
ARTERIAL STREET**

LEFT LANE CLOSED

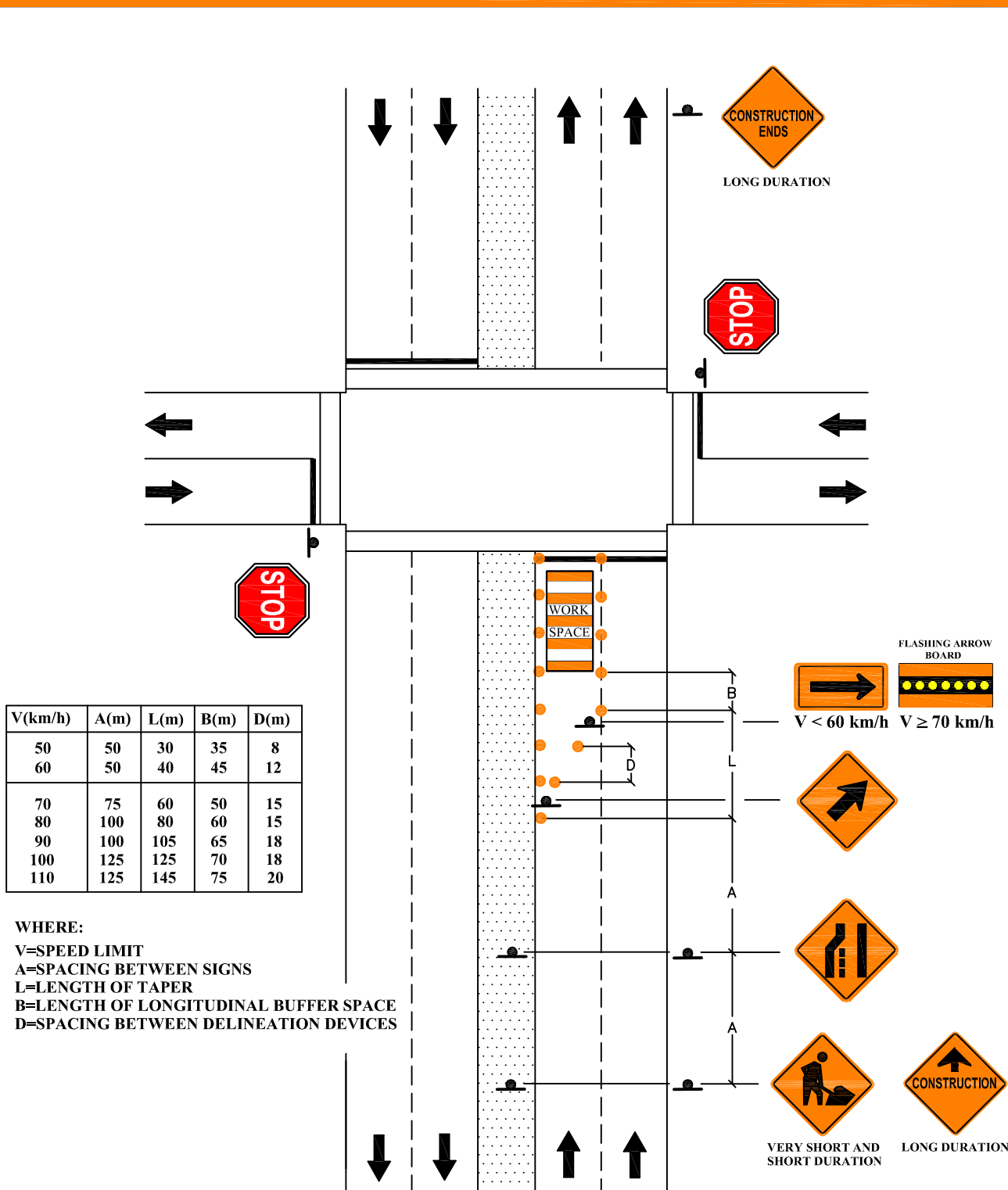

NOT TO SCALE

**CITY OF BRANDON
ENGINEERING DEPARTMENT**



DATE: AUGUST 01, 2001
 REVISED: FEBRUARY 10, 2006
 DRAWING #: TCM SECTION 6.20

REFERENCE MUTCD: FIGURE D4 - 53

**INTERSECTION NEAR SIDE LANE
CLOSED ON MULTI-LANE ROADS**

**COLLECTOR STREET AND
ARTERIAL STREET**

RIGHT LANE CLOSED

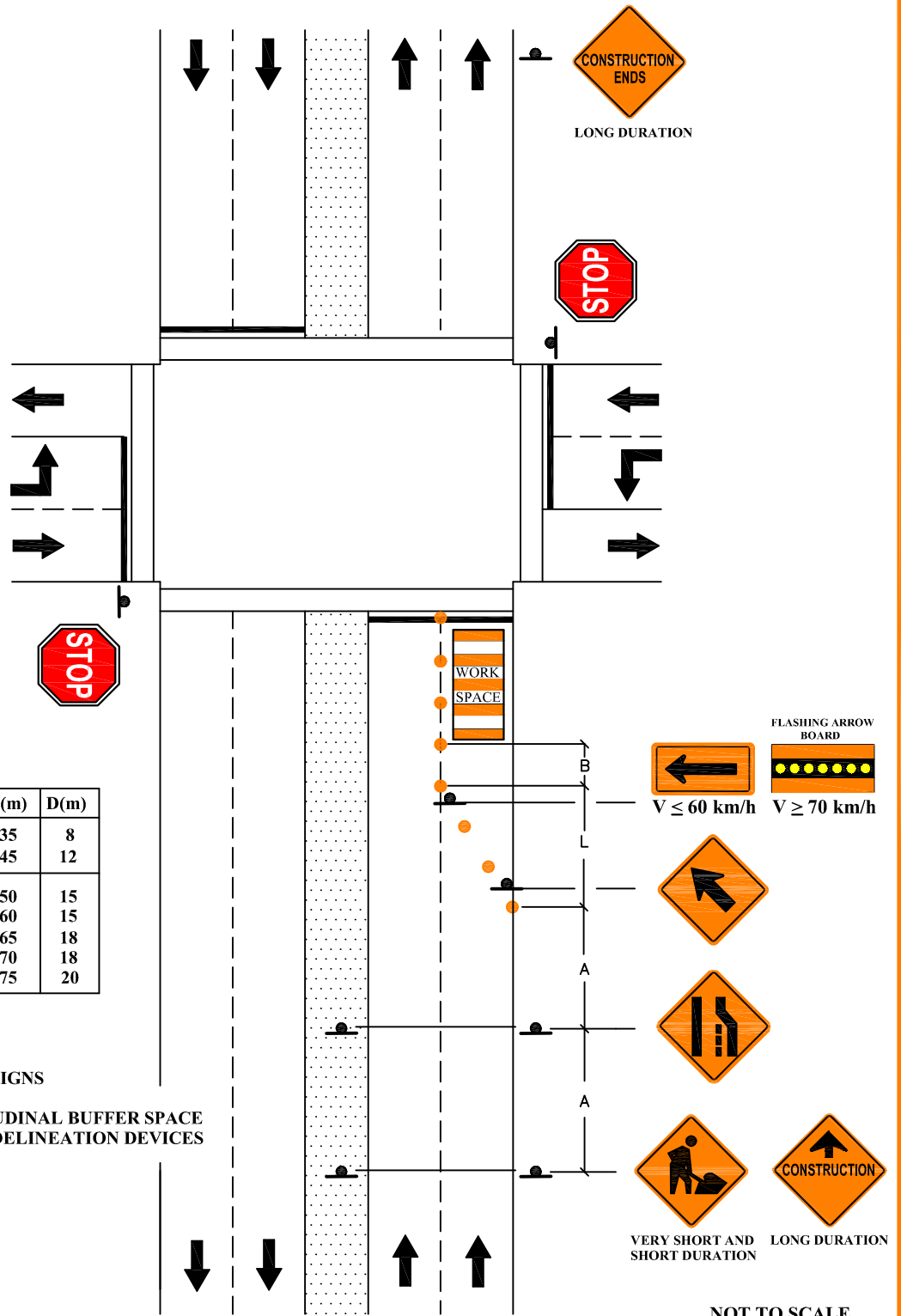

V(km/h)	A(m)	L(m)	B(m)	D(m)
50	50	30	35	8
60	50	40	45	12
70	75	60	50	15
80	100	80	60	15
90	100	105	65	18
100	125	125	70	18
110	125	145	75	20

WHERE:
 V=SPEED LIMIT
 A=SPACING BETWEEN SIGNS
 L=LENGTH OF TAPER
 B=LENGTH OF LONGITUDINAL BUFFER SPACE
 D=SPACING BETWEEN DELINEATION DEVICES

NOT TO SCALE

**CITY OF BRANDON
ENGINEERING DEPARTMENT**



DATE: AUGUST 01, 2001
 REVISED: FEBRUARY 10, 2006
 DRAWING #: TCM SECTION 6.21

REFERENCE MUTCD: FIGURE D4 - 54

INTERSECTION FAR SIDE LANE CLOSED ON MULTI-LANE ROADS

COLLECTOR STREET AND ARTERIAL STREET

LEFT LANE CLOSED

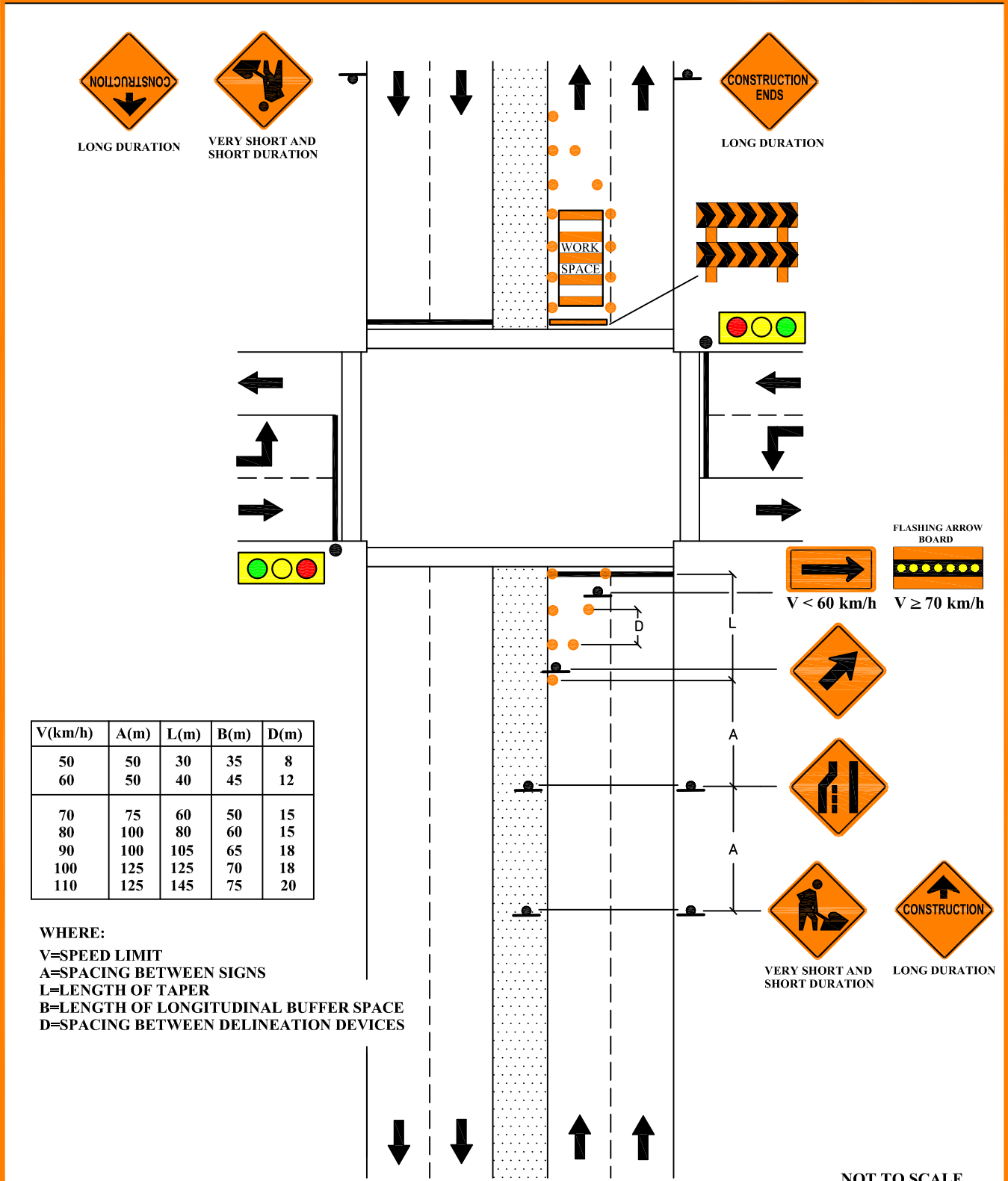

CITY OF BRANDON
ENGINEERING DEPARTMENT



DATE: AUGUST 01, 2001
 REVISED: FEBRUARY 10, 2006
 DRAWING #: TCM SECTION 6.22

REFERENCE MUTCD: FIGURE D4 - 61

INTERSECTION FAR SIDE LANE CLOSED ON MULTI-LANE ROADS

COLLECTOR STREET AND ARTERIAL STREET

RIGHT LANE CLOSED

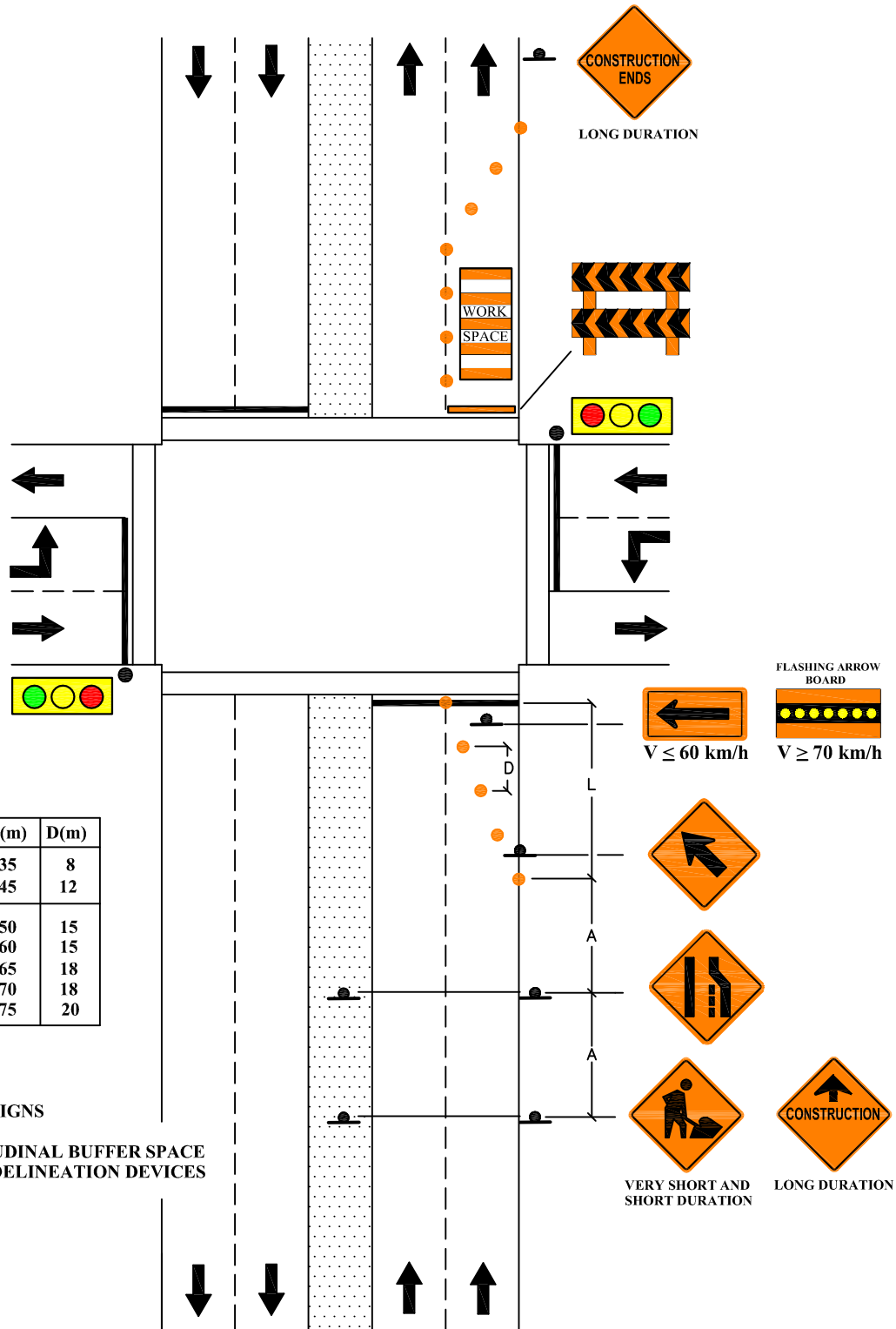

V(km/h)	A(m)	L(m)	B(m)	D(m)
50	50	30	35	8
60	50	40	45	12
70	75	60	50	15
80	100	80	60	15
90	100	105	65	18
100	125	125	70	18
110	125	145	75	20

WHERE:
 V=SPEED LIMIT
 A=SPACING BETWEEN SIGNS
 L=LENGTH OF TAPER
 B=LENGTH OF LONGITUDINAL BUFFER SPACE
 D=SPACING BETWEEN DELINEATION DEVICES

FLASHING ARROW BOARD
 $V \leq 60 \text{ km/h}$
 $V \geq 70 \text{ km/h}$

VERY SHORT AND SHORT DURATION
 LONG DURATION

NOT TO SCALE



INTERSECTION NEAR SIDE ALL LANES CLOSED ONE DIRECTION ON A MULTI-LANE ROAD

COLLECTOR STREET AND ARTERIAL STREET

ONE DIRECTION-LANE CLOSED

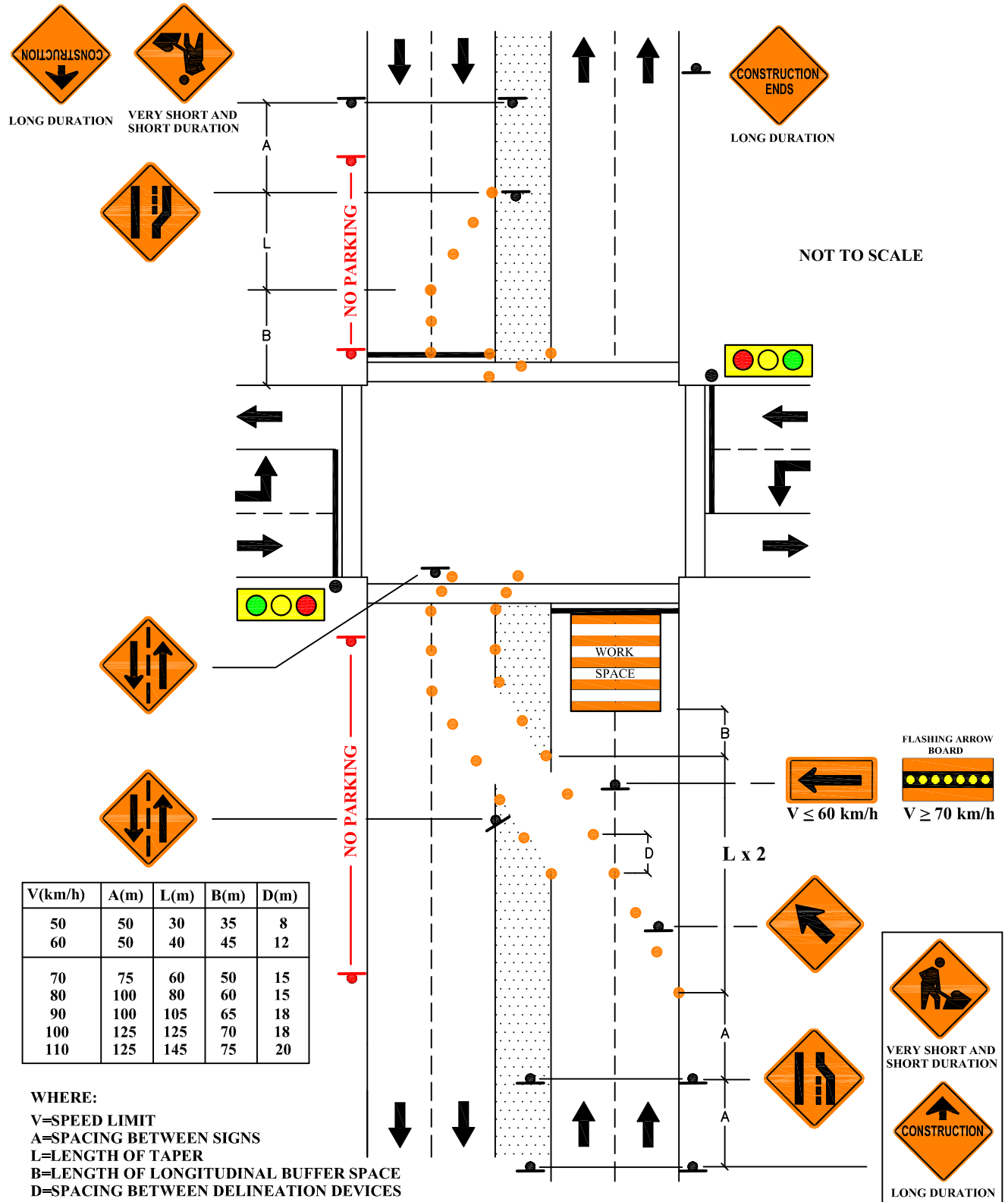

INTERSECTION FAR SIDE LANE CLOSED ON MULTI-LANE ROAD

COLLECTOR STREET AND ARTERIAL STREET

LEFT LANE CLOSED and NEAR-SIDE LEFT-TURN LANE OPEN

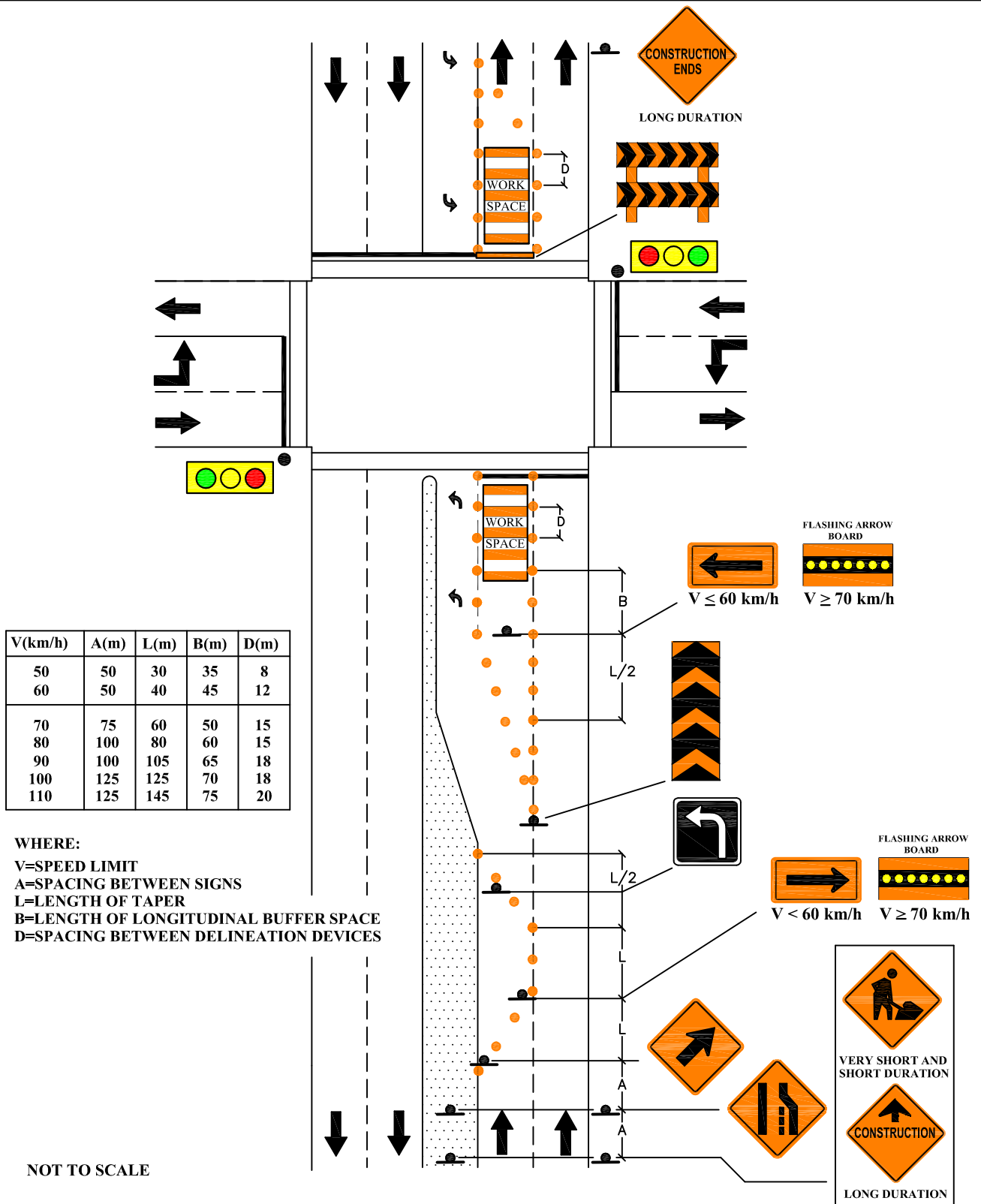

CITY OF BRANDON
ENGINEERING DEPARTMENT



DATE: AUGUST 01, 2001
 REVISED: FEBRUARY 28, 2006
 DRAWING #: TCM SECTION 6.25

REFERENCE MUTCD: FIGURE D4 - 63

**MEDIAN CROSSOVER
ON MULTI-LANE ROADS**

**COLLECTOR STREET AND
ARTERIAL STREET**

MID-BLOCK LOCATION

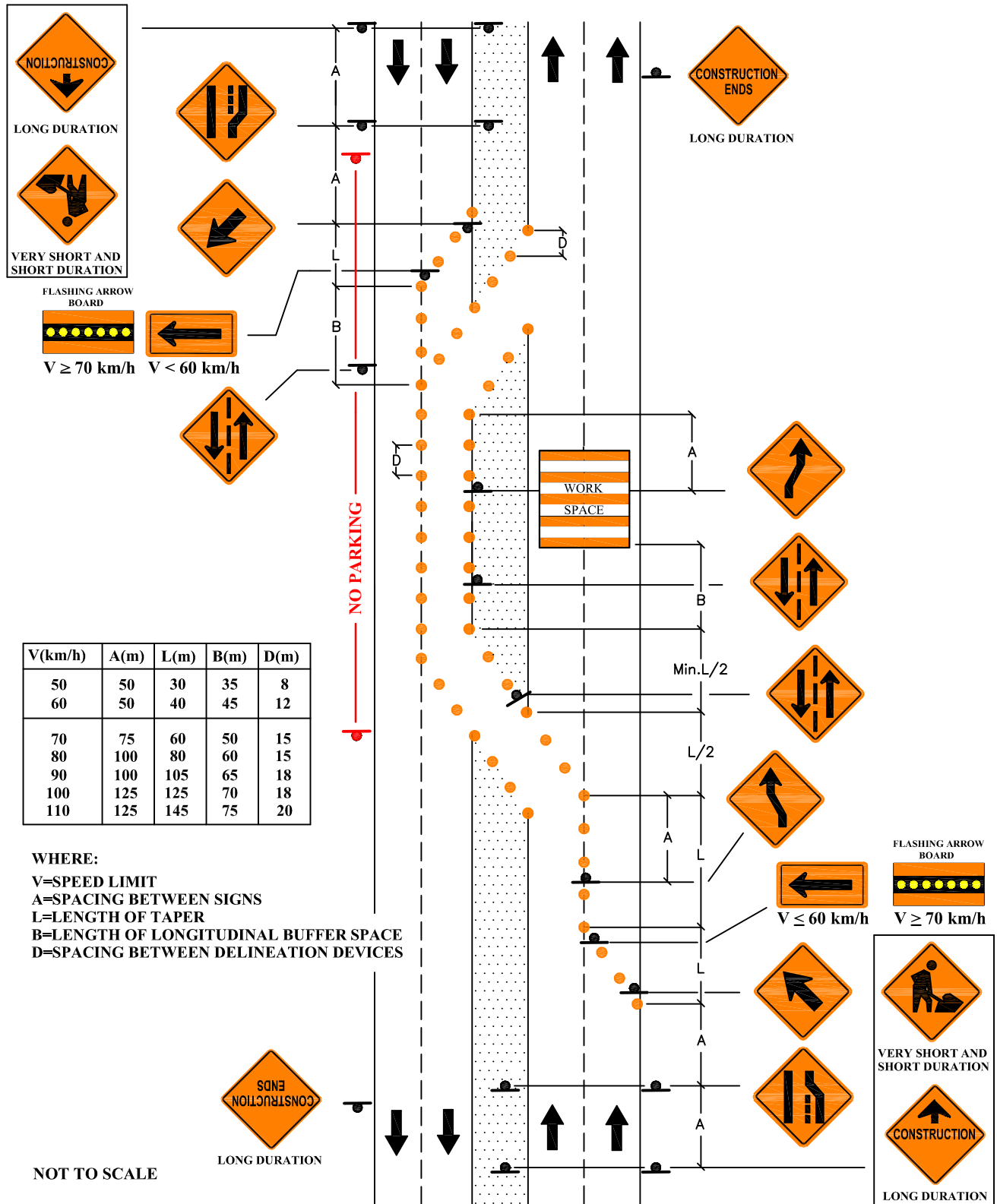

**CITY OF BRANDON
ENGINEERING DEPARTMENT**



DATE: AUGUST 01, 2001
 REVISED: FEBRUARY 10, 2006
 DRAWING #: TCM SECTION 6.26

REFERENCE MUTCD: FIGURE D4 - 42

ALL LANES CLOSED AT MID BLOCK

RESIDENTIAL STREETS

TOTAL ROAD CLOSURE

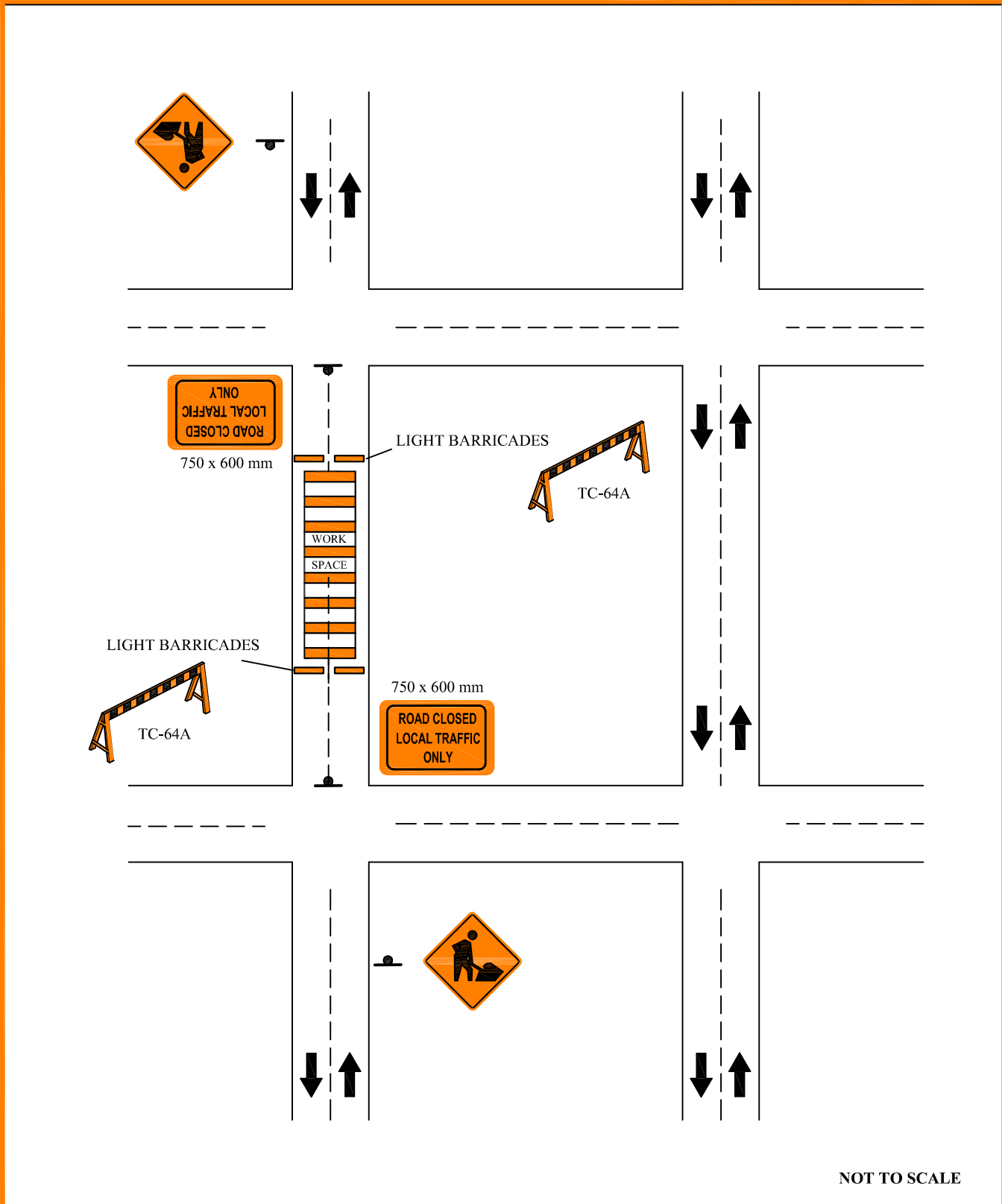

NOT TO SCALE

CITY OF BRANDON
ENGINEERING DEPARTMENT



DATE: AUGUST 01, 2001
REVISED: FEBRUARY 10, 2006
DRAWING #: TTCM SECTION 6.27

**DETOUR
ALL LANES CLOSED AT MID BLOCK**

**COLLECTOR STREET AND
ARTERIAL STREET**

TOTAL ROAD CLOSURE

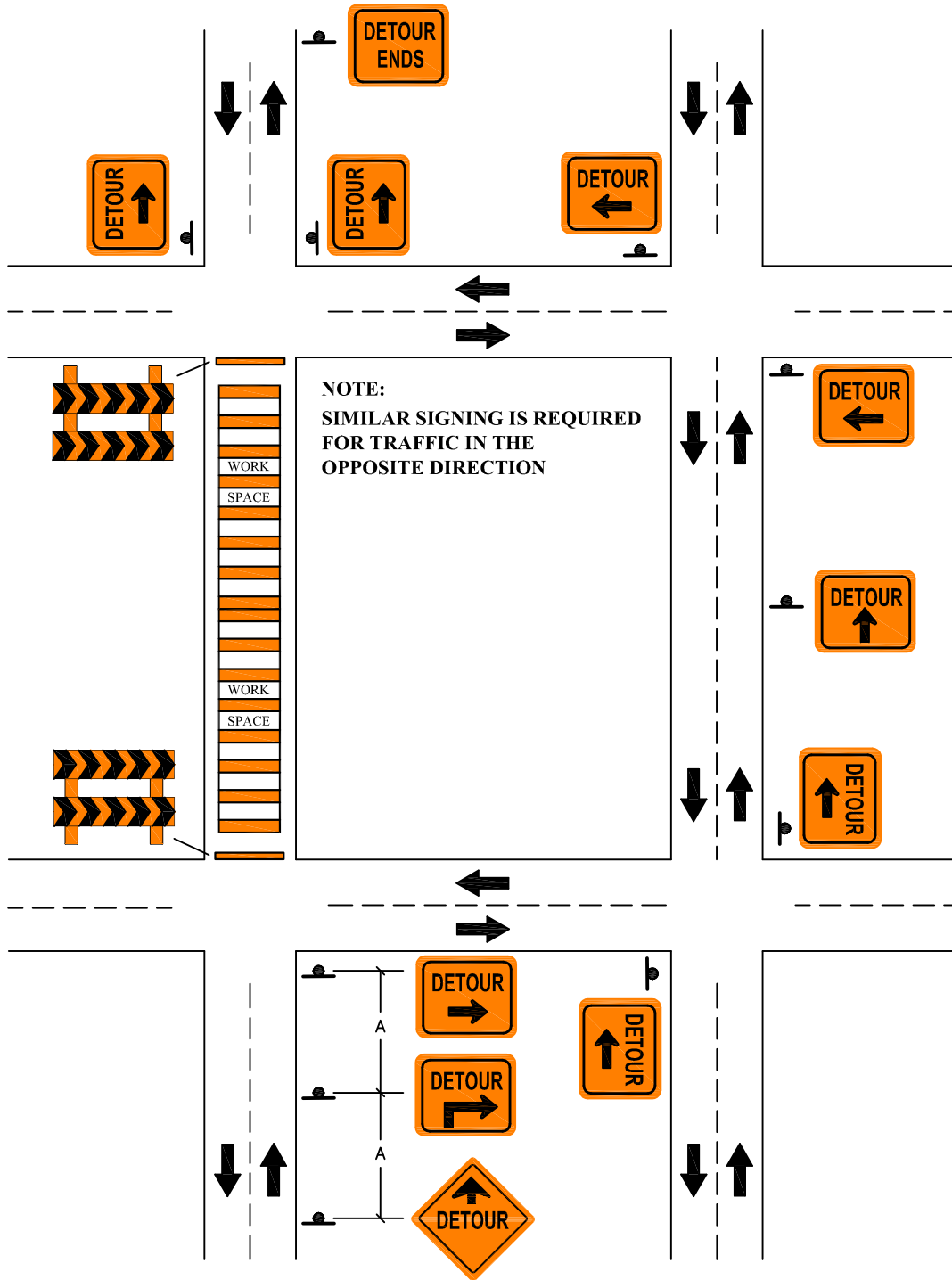

NOT TO SCALE

**CITY OF BRANDON
ENGINEERING DEPARTMENT**



DATE: AUGUST 01, 2001
REVISED: FEBRUARY 10, 2006
DRAWING #: TCM SECTION 6.28

REFERENCE MUTCD: FIGURE D4 - 44

**PEDESTRIAN CONSIDERATIONS
SIDEWALK DETOUR ONTO A ROAD**

**RESIDENTIAL STREET AND
COLLECTOR STREET**

MID-BLOCK LOCATION

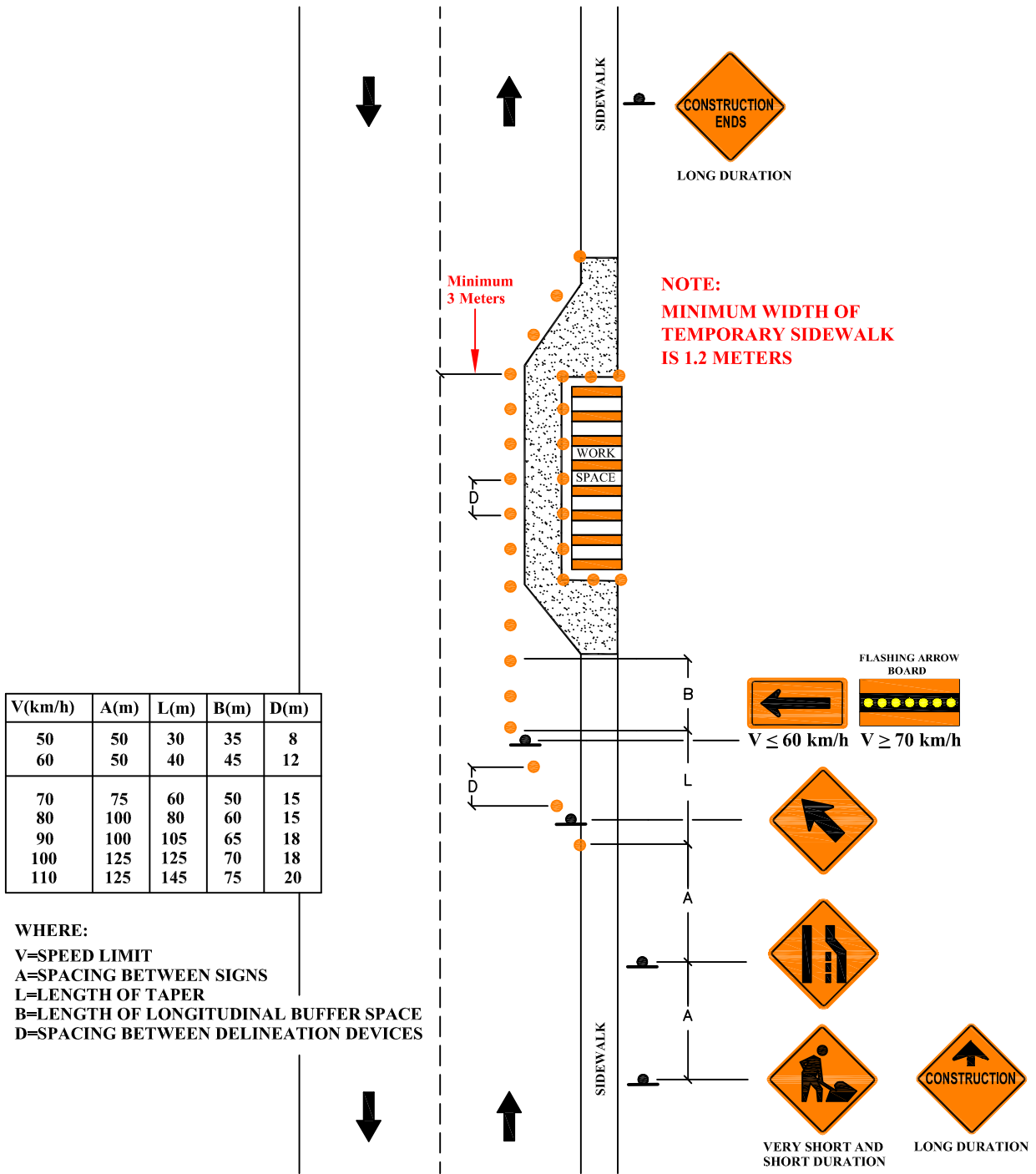

NOT TO SCALE

